



# District Tree Strategy 2010



*Sophora microphylla* "Kowhai"





## Executive Summary

The District Tree Strategy specifies those principles, policies and objectives associated with the long term management by the Matamata-Piako District Council of trees on Council administered land.

The document is to assist, with the management of trees in urban and rural settings and developments.

The Tree Strategy will provide philosophy, mandate and rationale for the management and advocacy for trees in both urban and rural environments. It should be read in conjunction with and complementary to other strategies and legislation including:

- Environment Waikato Regional Strategy
- Matamata-Piako District Council Tracks Strategy
- Matamata-Piako District Council Reserve Management Plans

Outcomes will include:

- Identify, record and register all trees on Parks, Reserves, and Cemeteries
- Planned preventative maintenance programmes
- Trees identified by location throughout the district
- Full replacement renewal policy
- Trees that are suitable to specific areas within the district
- Recommendations for further urban renewal development and residential property planting on private land
- Complements the statutory schedule of protected trees under the District Plan, both Council owned and those trees contained on private land

**Aims:**

- To recognise the importance of tree planting in achieving a high quality landscape
- To provide for appropriate planned tree planting in the Matamata-Piako District
- To maintain and enhance the amenity, landscape, historical, cultural and botanical value of all trees on Council land, Parks, Reserves, Cemeteries, Esplanades, Street Trees, Corporate buildings.
- To avoid the adverse effects of trees for new plantings
- To mitigate or remedy the adverse effects of trees growing on existing areas
- To complement the Reserve Management Plans where the plans have a specific policy for the management of trees on reserves.

# Contents

<b>Executive Summary .....</b>	<b>3</b>
<b>Contents .....</b>	<b>4</b>
<i>Composition and format of the District Tree Strategy.....</i>	<i>6</i>
<i>Guide to Section 2: Objective and Policies.....</i>	<i>7</i>
<b>Part One.....</b>	<b>8</b>
<i>Section 1 - Trees – A Valuable Asset.....</i>	<i>8</i>
1.1 Council’s Stewardship Role.....	8
1.2 The Relationship Between the Long Term Council Community Plan/Long Term Plan and the District Tree Strategy .....	9
1.3 The Relationship Between the District Plan and District Tree Policy .....	12
1.4 Principles of tree management in Matamata-Piako District .....	14
<i>Section 2 - Policies and Procedures for the Management of Trees .....</i>	<i>18</i>
2.1 General policies for the management of trees on Matamata-Piako District Council managed land. ....	18
2.2 Street Tree Management.....	39
2.3 Management of Tree Collections .....	42
2.4 Council Owned Management of Bush Remnants .....	45
2.5 Commemorative Trees .....	52
2.6 Planning and Management of Trees during Subdivision and other Types of Development .....	55
2.7 Consultation and Dispute Resolution .....	60
2.8 Education and Promotion .....	64
2.9 Tree Evaluation and Assessment.....	66
<b>Part 2.....</b>	<b>68</b>
Arboriculture - Operations Manual.....	68
Introduction .....	69
1.0 Arboricultural Operations.....	69
2.0 Tree Establishment.....	71
3.0 After-Care Maintenance .....	83
4.0 Pruning .....	87
4.1 Modern Arboriculture .....	88
5.0 Tree Removals .....	99
6.0 Debris Collection and Removal .....	104
7.0 Additional Arboricultural Operations .....	106
7.2 Cable Bracing and Propping.....	107
<b>Part Three.....</b>	<b>109</b>
<i>Guidelines for works within the vicinity of Trees .....</i>	<i>109</i>
Introduction .....	109
1.0 How Trees Function .....	110
2.0 Tree Parts Above Ground.....	110
3.0 Tree Parts Below Ground .....	112
4.0 Typical Root System.....	114
5.0 Wound Response .....	115
6.0 Damage to Trees.....	115
7.0 Above Ground Damage.....	116
8.0 Below Ground Damage .....	118

9.0 Tree Protection and Care .....	121
10.0 Protective Fencing.....	121
11.0 Installation of Utility Services.....	123
11.1 Thrusting and directional drilling.....	123
<b>Part Four.....</b>	<b>125</b>
<i>Appendices</i> .....	125
Appendix 1 Trees that should be excluded from road reserves.....	125
Appendix 2 Guide to consider the request for tree removal.....	126
Appendix 3 Profile and Street Tree Selection Criteria.....	127
Appendix 4 Species Selection .....	129
Appendix 5 Wilful Damage to Council Trees.....	131
Appendix 6 Tree Removal .....	132
Appendix 7 Tree Planting .....	134
Appendix 8 Guide for developers .....	136
Appendix 9 Planting Guide for Residential Sections.....	142
Appendix 10 Your Rights - Trees, Fences and Your Neighbours .....	147
Appendix 11 Sample tree evaluation form and report.....	151
Appendix 12 Guide to shrubs groundcovers and rain garden plants .....	173
3.0 Glossary.....	175
Acknowledgements .....	182

## ***Composition and format of the District Tree Strategy***

**The tree strategy is in four parts**

- **Part 1** is a public policy document, specifying those principles, policies and objectives that guide the Council's ongoing protection and management of tree resources owned and or administered by the Matamata-Piako District Council.
- **Part 2** contains operational and technical guidelines and additional information to support the policies defined in the District Tree Strategy - Part 1 and serves as a working document for Council officers.



**Mt Te Aroha**

- **Part Three** contains the operational and technical guidelines for working in the vicinity of trees including basic botany, growth patterns and technical data.
- **Part Four** contains the appendices as outlined in the table of contents.

These documents are for the benefit of staff and public alike and include recommendations for tree planting, species and selection, the requirements for requesting services and details on your rights.

## **Guide to Section 2: Objective and Policies**

The following structure has been applied throughout Section 2 Objectives and Policies:

### *Title of Section*

This text indicates the general topic

#### **Subtitle**

This text indicates the sub-topic within the general topic area.

#### **Objective number**

This text defines the management aim (or goal) the Council seeks to achieve.

#### **Policy**

This text clarifies the way in which the Council will achieve its management aims or which policies it will follow.

#### **Explanation**

This text outlines why the Council considers the objectives and policies are necessary.



***Cercis canadensis* “Forest Pansy**

## Part One

### ***Section 1 - Trees – A Valuable Asset***

#### **1.1 Council’s Stewardship Role**

The Matamata-Piako District Council (MPDC), as steward of the district’s public tree resource, currently manages the care and maintenance of street trees and countless specimen trees in parks, reserves and on other Council administered lands. The Council takes a proactive approach, by regularly planting new trees on public land primarily to maintain and replenish the numbers of street trees and specimen trees in parks and reserves. The Council does not manage trees on private property, with the exception of some responsibilities related to trees formally protected under the District Plan.

Trees are a living resource and, as such, their care requires ongoing decisions regarding maintenance, replacement, renewal, and removal. Council arborists apply their knowledge of the specific life requirements of each tree species to ensure the “right tree for the right place”, with the goal of creating healthy and attractive treescapes now and into the future. Careful planning is also required to minimise the potential for future problems with properties, services and infrastructure as the trees grow.

The Council approach recognises that some trees are of high value due to their species, age, history, uniqueness and contribution to the landscape while other trees are of lower value and can be removed or replaced if required. The District Tree Strategy and District Plan contain policies and provisions to ensure consistency in methods of evaluation of trees and decision-making on issues related to tree management.

Council staff are dedicated to working cooperatively within Council departments and the community to provide healthy, viable trees and treescapes in the district over the long term. Where issues arise concerning tree management, the Council is committed to identifying fair solutions that reflect the value of a tree or treescape to the community while addressing, to the extent possible, the concerns and interest of individual residents.

## **1.2 The Relationship Between the Long Term Council Community Plan/Long Term Plan and the District Tree Strategy**

The Long Term Council Community Plan (LTCCP/LTP) is the planning and policy document for the MPDC. The LTCCP lists nine community themes, developed through public consultation, to guide priorities for the Council delivery of services over the active term of the plan. The LTCCP goals and objectives are taken into account to achieve this Tree Strategy.

### **Goal one - Community Outcome Theme 1.0 Well being of our community**

#### **1.3 Participating in decision-making**

- (a) All people will have the opportunity to comment on the decisions that affect their lives
- (b) Young people will be involved in local decision making at a range of levels
- (c) Tangata whenua with Mana whenua status are recognised and involved in decision-making

#### **1.4 Promotion of citizen responsibility**

- (a) All residents will recognise their responsibility to contribute to our district being a great place to live
- (b) People will feel that there is a strong sense of 'community responsibility'.

### **Goal two - Community Outcome Theme 3.0 Economic development: Prosperity**

#### **3.3 Tourism**

- (a) The tourism potential in our district is recognised, developed and well coordinated for the benefit of all
- (b) Tourism will become the focal point for Te Aroha with the town becoming recognised as more of a 'destination'
- (c) While developing tourism the character of our towns will be preserved and economic diversity will be developed
- (d) Our communities and their attractions will be well promoted to tourists and potential residents both nationally and internationally

### **Goal three - Community Outcome Theme 4.0 Healthy air, water, land: Healthy people**

#### **4.5 Protecting the landscape**

- (a) The district will continue to maintain an attractive landscape that is not altered by the adverse visual effects of development
- (b) All development would seek to avoid, remedy or mitigate the visual impact of development
- (c) Attention will be given to promoting, protecting and regenerating our native flora and fauna

#### **4.6 Water quantity and quality**

- (a) Our rivers and water supplies will be clean and safe for industrial, business and residential consumption, cultural purposes and recreational uses
- (b) The mauri of all waterways will be maintained in optimum condition
- (c) Systems will exist to sustainably provide enough water for all purposes at all times
- (d) People will be aware of the issues threatening their access to clean water for both drinking and recreation

#### **Goal four- Community Outcome Theme 5.0 Heritage: Our past**

##### **5.1 Built heritage**

- (a) The built heritage of our towns and district will be protected, enhanced, promoted and celebrated by the local community

##### **5.4 Te Aroha Domain**

- (a) The Domain will be developed in a manner to link the river, the main street of town, Herries Park and the Domain into a holistic town feature
- (b) The Domain and its facilities will be well utilised and enjoyed by residents and tourists while remaining affordable for residents
- (c) The Domain will be well advertised and promoted through organised events

##### **5.5 Wetlands, significant natural features and wahi tapu**

- (a) The wetlands, significant natural features and wahi tapu on public land throughout the district will be protected, promoted enhanced and restored
- (b) The wetlands, significant natural features and wahi tapu on private land throughout the district will be protected, promoted and enhanced for preservation purposes

#### **Goal five - Community Theme number 6.0 our social infrastructure**

##### **6.2 Services**

- (g) Community organisations that are making a valuable contribution to our community's wellbeing are well resourced for the work they do.

## Goal six - Community Outcome Theme 7.0 Planning and development

### 7.5 Town appearance

- (a) Our towns will have an appearance their residents can take pride in; free from graffiti and vandalism
- (b) The town entrances will be maintained as gateways to the town, with a theme appropriate to the town
- (c) Our towns will have wide streets and well maintained footpaths
- (d) Industry will be zoned to appropriate places within the town with screening and development controls in place to help reduce the visual impact
- (e) The appearance of our towns, the names of roads, sites and facilities, will reflect the diversity of the residents

### 7.6 Town planning

- (a) Our District Plan and Council policies will promote the retention of the character of our towns while accommodating growth and development

## Goal seven – Community Outcome Theme 8.0 Pride and justice

- (c) People will be able to feel proud of their heritage and culture

### Māori World View

Tangata whenua have a relationship with trees through whakapapa. Tane is considered one of the most important tipuna in the Maori world view for he created all mankind and his marriage to different deities also produced different species of trees.

In the Maori world view, Tane has authority over the forests, bush, birds and trees and is recognised through the whakatauki 'Te wao tapu nui a Tane' or 'The great sacred forest of Tane'. This whakatauki serves as a reminder of the strict rules of tapu that **apply to the forest and its inhabitants** and therefore trees must not be felled without obtaining permission from Tane through karakia, chants or offerings. To transgress such tikanga (protocol) would mean you are treating your ancestor and relatives inappropriately.

Referenced from:

Coming of the Māori by Sir Peter Buck

Exploring Māori Values by Joan Patterson

Te Ara – The Encyclopaedia of New Zealand

### 1.3 The Relationship Between the District Plan and District Tree Policy

The **District Plan** provides the statutory mechanism for the protection of district trees, as directed by the Resource Management Act (1991). The provisions in the District Plan apply to public and private lands.

The **District Tree Strategy** only applies to trees on public lands that are owned and/or administered by the Matamata-Piako District Council. The **District Tree Strategy** provides policies and guidelines for the management of trees on Council land, but these do not carry the weight of law. The policy cannot override the statutory responsibilities in the District Plan or Acts and Regulations under New Zealand law.

The **District Tree Strategy** advocates for the protection of trees through education, advice and promotional activities but does not apply additional policy for the management of trees that are protected under the District Plan

#### District Plan

#### District Tree Strategy

<p>Purpose: Regulatory and non-regulatory provisions for the protection and maintenance of trees on private and public lands, through:</p> <ul style="list-style-type: none"> <li>• Identification of Notable Trees in a schedule in the District Plan,</li> <li>• Identification of Significant Natural Areas in a schedule in the District Plan, applying standards in the District Plan</li> <li>• Placing conditions on resource consents, and</li> <li>• Education and advice to landowners.</li> </ul> <p>Administered by: Planning</p>	<p>Purpose: Recognition, strategic planning, management and long-term continuity of the tree resource on public lands owned and/or administered by the Matamata-Piako District Council, with particular emphasis on:</p> <ul style="list-style-type: none"> <li>• Individual and groups of trees on Council reserves and public open spaces</li> <li>• Trees on road reserves.</li> <li>• Maintenance/Documentation of notable trees on private land</li> </ul> <p>Administered by: Community Facilities</p>
---	--

**Figure 1.** Relationship between District plan and the District Tree Strategy

**Notable Trees** are protected under the Resource Management Act due to their significance for historic, botanical, landscape, amenity or cultural reasons. Notable trees can be on public or private property. Rules in the District Plan apply to the maintenance or removal of notable trees and activities within the dripline area.

The significance of notable trees is determined using a set of criteria outlined in Appendix 1(Section 2(a), (b), (c).) of the District Plan. Criteria include the health and vigour of a tree, its visual or landscape value, heritage value, botanical or rarity value, manageability in its location and the contribution to the overall ecology of the area.

**Significant Natural Features (SNFs)** are areas of indigenous vegetation that have been identified in the District Plan ([Appendix 1\(Section5 \)](#)) based on criteria to assess significance, such as species diversity, representativeness, presence of rare, vulnerable or endangered endemic species and important habitat



***Cordyline australis*** “Cabbage Tree”

## **1.4 Principles of tree management in Matamata-Piako District**

### *1.4.1 Trees in the Landscape*

**1.4.1.1** Trees are an essential component of our urban and rural landscapes. Their dynamic, organic nature gives them a short lived character when considered against the permanence of the urban areas and its structures.

The living nature of trees, and the need for continuity, makes the processes of replacement planting and ongoing planned renewal a critically important aspect of landscape management.

**1.4.1.2** Trees on Council land will be protected and managed to enhance the landscape. Whilst protecting trees is paramount to the principle of maintaining the quality of the present day landscape it should be recognised that trees are not everlasting permanent features. In order to avoid significant degradation of urban and rural tree cover it is necessary to maintain trees across a range of age classes, on streetscapes and within reserves and on an ongoing basis.

**1.4.1.3** Tree planting and management in streets, parks, reserves and Council-administered land throughout the district is vital to counterbalance the continuous changes occurring every day as a result of urban intensification, building development and roading improvements. Without such a cycle of replacement and renewal the incremental loss of trees will create temporary gaps and/or serious long-term reductions in tree cover and may lead to landscape degradation.

**1.4.1.4** Planting and replenishment of trees by residents on private property is a significant part of the constantly changing and improved landscapes in the district. However, trees on private property should not be relied upon to maintain the appearance of the district's urban and rural landscapes – only to augment it. A strategy to provide private property with a comprehensive suitable schedule of trees will assist in the co-operation and perception of the public to Council led initiatives. A significant benefit in broad-scale landscape improvements arises from the Council engaging in well planned and coordinated plantings on Council administered land. Public and private plantings together combine to create tangible and enduring environmental and amenity benefits for the district.

**1.4.1.5** Trees will be managed to ensure their health and well being. Urban trees require specialised ongoing management in order to assist their survival in the highly-modified built environment. Towns and cities are often high stress environments for trees, which have generally evolved in the more conducive natural growing environments of the forest, wetland or open plains. Trees under stress – be it from water deficit, soil compaction, low nutrient levels, air pollution, elevated air temperatures, altered light levels or physical damage – are more susceptible to pests and diseases and will frequently exhibit a shortened life span. As a significant asset of the Council, maintaining existing mature urban trees in healthy condition is economically preferable to establishing new trees in the same location.

Trees are an asset to the Council and community settings.

The Council takes a positive approach to planting trees in public areas to maintain district tree assets now and into the future.

## 1.4.2 The Benefits Derived from Trees

**1.4.2.1** Trees provide multiple benefits. These are generally summarised as aesthetic, environmental, climatological, ecological, economic and social factors. Trees can be used in our urban and rural landscapes to achieve substantial positive outcomes for the community and visitors alike.

**1.4.2.2** Trees have the ability to reinforce the local identity and character of a place, provide visual unity, and soften the often harsh and sometimes visually chaotic built character of our urban environments. As such, trees are an important tool in the urban design.

In addition the natural and cultural heritage values of valuable, old trees, provides an important depth of meaning and history within the landscape. Due to their longevity, trees provide recognizable landmarks that link generations.

**1.4.2.3** Trees and associated undergrowth also assist in modifying and improving some of the less desirable aspects of urban environments such as air pollution, degraded water quality, water run-off, convection or reflected heat, wind exposure, and erosion.

**1.4.2.4** Trees provide substantial benefits in relation to the ecological health and sustainability of our urban built environments. Urban vegetation, including trees, understory shrubs and ground cover, provides habitat for indigenous plants, insects and bird life. The air, water and nutrient exchange processes undertaken by trees are fundamental to human existence and the continuity of the food web which supports all life on earth.

**1.4.2.5** Urban trees improve the environment by absorbing, filtering and purifying the basic elements of air and water. Their continuous metabolic processes improve the adverse effects of sun, wind, rain, dust and pollution, softening the harshness of the urban environment, providing shade and reducing the energy needs of the urban areas.

**1.4.2.6** Trees have an important function in providing shade and thereby reducing peoples' exposure to ultraviolet radiation. Shade from trees also provides cool areas to escape from summer heat when recreating or resting in the outdoors as well as providing shaded areas for cars to park.

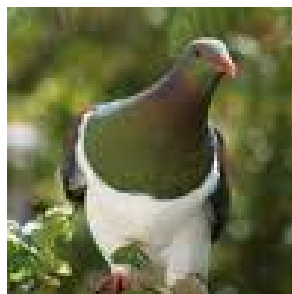

***Kereru* “ New Zealand Native Wood Pidgeon”**

### *1.4.3 The Management of Trees in the Urban Environment*

**1.4.3.1** The Council manages trees professionally and objectively, based on established methods of arboriculture. Managing trees not only requires planting and maintaining trees to expand the tree resource; it is also often necessary to modify or remove trees that are causing problems.

**1.4.3.2** It is undeniable that trees in urban locations can create problems of a physical nature.

Examples include:

- Limitation on development potential.
- Interference with underground and overhead services.
- Disruption to structural foundations
- Difficulty of access.
- Leaf fall blocking drains and stormwater channels.
- Traffic safety issues related to reduced visibility, excessive shading and obstruction of views.

Additionally, trees can cause problems more of a social nature, such as safety issues associated with the visibility of street lights and disputes over leaf litter, shading and views. In such circumstances, it is necessary to explore ways to manage the treescape so that people and plants can co-exist.

**1.4.3.3** Occasionally, trees in close association with buildings and services can cause genuine difficulties. However, with good planning, creative development design and the selection of appropriate species these perceived 'problems' are largely avoidable.

- Wherever street trees exist, or are proposed, the potential conflict with utilities and roading assets is assessed prior to any decision to retain, maintain or remove trees.
- Likewise, urban developments are created in consideration of the space required to allow the successful establishment and retention of trees and other vegetation. Usually, many of the adverse effects generated by trees are more than mitigated by the substantial environmental and aesthetic benefits they provide.

**1.4.3.4** Strong community interest in environmental issues and general support for the provision of green residential and urban amenity means that, more than ever, the Council must strike the appropriate balance between the management and protection of valuable vegetation and the avoidance of real and perceived detrimental effects associated with trees.

- In its decision-making on trees, the Council considers the implications for all members of the community, including immediate neighbours, local residents, community members and visitors to the area, recognising that all receive some level of benefit and use from having a treescape environment.

## **Section 2 - Policies and Procedures for the Management of Trees**

### **2.1 General policies for the management of trees on Matamata-Piako District Council managed land.**

This section contains general policies that apply to the management of all trees on Council administered lands within the MPDC district. Types of Council trees include individual trees and groups of trees on street, roadside reserves and in Council reserves. Specific policies have been developed for the management of street trees, tree collections, commemorative trees and bush remnants.

Categories of Council trees include the following:

- **Street trees** are formal plantings along Council road reserves, with the intent of creating managed streetscapes. Streetscapes are planned in consultation with local residents and in keeping with the “street character area” themes for the district. These trees have been planted or accepted by Council, with the intention of providing amenity value to the neighbourhood and towns generally. They are also planned to be ‘sustainable’ (see definition below). These can be classed into Avenue trees, suitable for the urban residential and commercial areas or Gateway Trees for main road linkages
- **Road reserve trees** are trees situated on road reserves that have not been formally planted. There are two categories of street and road reserve tree:
  - **Sustainable:** These are trees that are considered, through established assessment methods, to be ‘manageable’ in relation to surrounding activities, services, assets, properties and infrastructure.
  - **Unsustainable:** These are trees that are determined, through established assessment methods on an as-needs basis, to have an unmanageable level of interference with surrounding activities, services, properties and infrastructure.
- **Tree collections** are groups of trees formally planted and managed at a site to enhance the diversity and value of the district tree asset. Collections may be single or multiple species such as the Centennial Drive in Matamata and Hetana Street Reserve in Matamata.
- **Bush remnants** are areas of indigenous (native) vegetation that represent the original habitat type of an area. These remnants contribute to the aesthetic value of the district and to local biodiversity.
- **Commemorative trees** are trees planted on public land to commemorate a person or event. Trees are also donated by individuals and organisations.

## 2.1.1 Tree Selection and Planting

### Objective 2.1.1.1

Council tree planting will ensure:

The existing distinctive landscape characters of the district are reinforced, using species appropriate to the location and site.

### Policy 2.1.1.1 (a)

Tree species will be selected that are appropriate to:

- a) The growing conditions of the site but that also are most suited to meet the objectives for the planting (e.g., amenity value, shade provision, trees to attract native bird species).
- b) Exotic species, natives, or a mixture of both may be used to achieve this objective.

### Policy 2.1.1.1 (b)

Existing district wide planting themes established for the urban areas of the district shall be implemented.

### Policy 2.1.1.1 (c)

The long-term cost impacts associated with ongoing maintenance shall be considered.

### Policy 2.1.1.1 (d)

Selected exotic species must be planted, to contrast native plantings

- To emphasize the diversity of the vegetation of the district.

### Policy 2.1.1.1 (e)

Local character species must be used to

- Provide a backdrop and framework for the planting of a range of selected species,
- Enhance open space.
- Appropriate species may be those associated with coastal, lowland or wetland areas.

### Explanation

Within the district there are distinctive landscape character areas that are reflected by the nature of its vegetation. District wide planting themes have been established for the urban areas of the district. For example, our district has a heritage that favours plantings of exotic trees.

### Objective 2.1.1.3

To provide distinctive landscapes of mature trees, throughout urban areas

#### Policy 2.1.1.3 (a)

Potentially large trees may be planted wherever appropriate space permits.

#### Policy 2.1.1.3 (b)

Plantings will be designed using the correct choice of species and position.

#### Policy 2.1.1.3 (c)

Trees of longevity and heritage value should be planted, incorporating, where possible, nursery stock material specially propagated from existing notable and/or character trees.

#### Policy 2.1.1.3 (d)

Council staff will consider available information on local flora and fauna when planning and selecting tree-related works, including tree species selection for plantings.

### Explanation

There has been a trend in some districts of New Zealand towards smaller residential lots as a result of infill subdivision and cross leasing. This has resulted in a reduction in large trees in urban areas, as residential sections are not large enough to contain substantial trees. Therefore, planting of trees that grow to ultimately large proportions will be implemented by the Council, wherever appropriate space permits, to ensure that the urban areas still contain substantial trees of long-term value.

#### Objective 2.1.1.4

To reduce the necessity for intensive maintenance of trees.

#### Policy 2.1.1.4 (a)

Council will give preference to planting species that:

- Are pest and disease resistant,
- Provide maximum environmental/ecological benefits,
- Have a proven track record for establishment and sustainability, and
- Require less maintenance, such as Arborcare, watering and mulching.

#### Policy 2.1.1.4 (b)

Council will plan plantings to ensure that:

- Only quality plant stock is used
- Standardised specifications and techniques and practices are used to install plant materials
- The correct species is chosen in relation to the limitations of the site.

#### Explanation

Choosing the most appropriate species for the conditions and particular aspects of the site can reduce long-term maintenance problems. By using quality plant stocks, planted effectively and appropriately for the site, many long-term maintenance liabilities can be avoided.



#### Objective 2.1.1.5

To increase the awareness and use of local native plants and locally-developed plant selections.

#### Policy 2.1.1.5 (a)

Local native species and locally developed plant selections and cultivars will be featured prominently where possible.

#### Policy 2.1.1.5 (b)

In selecting local native species for planting, consideration will be given to the ecological and habitat values provided by the species and its aesthetic and other amenity values.

#### Explanation

To ensure that we sustain the endemic species of this area, every endeavour is to be made to source seed and plant material from within the areas for natives and for locally developed cultivars of plants.



*Corynocarpus laevigatus* “Karaka”

#### Objective 2.1.1.6

To improve the aesthetic and amenity value of all areas for the public by designing future tree plantings to enhance, and be compatible with the environment while considering the interests of individual property owners.

#### Policy 2.1.1.6 (a)

Public plantings in all areas shall be designed to enhance the environments, with an awareness of the sensitivity of local landowners to their viewsapes.

#### Policy 2.1.1.6 (b)

Plantings will be compatible with the outcomes of public consultation processes, including

- Zoning and direction in strategic plans,
- Parks and Reserves Strategies,
- Reserves Management Plan
- Reserve development plans.

#### Policy 2.1.1.6 (c)

Consultation will be undertaken prior to plantings in areas where there are parties who are likely to be affected by or have an interest in the planting. This includes local residents and manawhenua. The breadth of consultation will be commensurate with the size of the planting and the potential number of affected parties.

(Refer to 2.7 Consultation and Dispute Resolution)

#### Policy 2.1.1.6 (d)

Tree planting will not occur where it may interfere or compromise or adversely affect the safety, efficiency and integrity of community facilities such as flood protection and river control works, radio and telecommunications networks.

#### Explanation

One of the challenges of managing the public tree resource is to provide the treescapes desired by the public while respecting the interests of local residents in having pleasing viewsapes.

#### Objective 2.1.1.7

To plan future plantings to minimise costs and potential for problems with services, assets, properties and infrastructure in the short and long term.

#### Policy 2.1.1.7 (a)

The design and selection for new tree planting shall be based on:

- The relationship of trees with their surroundings in terms of character, form, amenity and ecological value.
- The foreseeable effects of trees in relation to shade, views, services and potential damage to built structures.
- The scale of tree in terms of built structures and in relation to potential size and numbers of trees used in the design.
- The outcome, where applicable, of any request for service relating to street tree planting that is accepted by the Council, according to established procedures.
- The anticipated cost of successfully establishing new planted areas and the ongoing costs associated with maintenance.

#### Explanation

Trees are living; growing entities and they naturally change and develop over time. There are many inter-related factors that must be considered for all plantings. The design and planning of plantings creates a range of opportunities to address the constantly changing characteristics of plantings and the needs of potential new planting sites. More detailed direction on this issue is provided in Section 4.1.3: Interference of Trees with Community Facilities.

## 2.1.2 Tree Maintenance

### Objective 2.1.2.1

To promote and practice maintenance of Council trees to foster development of safe, healthy and natural tree form.

### Policy 2.1.2.1 (a)

The Council will not carry out topping of trees.

### Explanation

It may be necessary to remove the top growth of trees in the following circumstances:

- (a) Where trees are near power lines, in preference to removing the trees altogether. However, if identified as low value and high maintenance some consideration may be given to removal (see Policy 2.1.3.2(a)).
- (b) Where trees are considered a safety hazard and removal of the upper crown is deemed acceptable in order to alleviate the hazard and retain the tree(s).
- (c) Where trees interfere with radio or telecommunications facilities.
- (d) Where trees are undermining a flood protection or erosion control structure.
- (e) Where a group of trees constitutes a shelterbelt or hedge.
- (f) Street lighting where no alternative exists

### Policy 2.1.2.1 (b)

Acceptable pruning methods, such as natural target pruning, crown lifting and crown thinning may be used to maintain trees in as natural a form as possible and to maintain and enhance their amenity values e.g., opening up views or providing access to sunlight.

### Policy 2.1.2.1 (c)

Work on trees will be carried out to recognised and accepted contemporary arboricultural standards and consistent with current industry practices, including New Zealand Arboricultural Association (NZAA) and International Society of Arboriculture (ISA) guidelines, and the Approved Code of Practices for Safety and Health in Tree Work (Department of Labour).

### Policy 2.1.2.1 (d)

MPDC will develop and maintain an up-to-date list of approved arborists who meet Council recognised criteria.

#### Policy 2.1.2.1 (e)

Only Council approved arborists and contractors, having proven arboricultural skills, will be contracted to carry out tree maintenance work on Council trees in order to maintain industry acceptable standards of workmanship.

#### Policy 2.1.2.1 (f)

Sound arboricultural practices and appropriate care strategies will be applied to prevent pest and disease establishment and to maintain good tree health.

#### Policy 2.1.2.1 (g)

Plant pest and disease control measures shall focus on known aggressive decay organisms that have the capacity to debilitate or kill trees.

#### Policy 2.1.2.1 (h)

Work scheduling will occur based on the following order of priority (with #1 being the highest priority):

1. Health and structural safety of the tree,
2. Essential service clearance,
3. Form pruning for desirable clearance and amenity effects e.g., access to sunlight, views and reduction of leaf litter.

#### Explanation

Arboricultural practice is based on a number of well founded and evolving principles and methods. For example, there are a number of recognised pruning methods, including CODIT and Natural Target Pruning.

The Council is committed to maintaining trees in accordance with internationally recognised standards. Appropriate tree care maintenance programmes and strategies will be applied, wherever necessary.

Topping is internationally recognised as unsound arboricultural practice for the following reasons:

- (a) Vigorous regrowth from adventitious shoots at the site of each pruning cut results in a denser canopy developing in a short space of time. This causes excessive shading, often greater than that previously experienced.
- (b) The points of attachment of new sucker growth have an inherent weakness and, therefore, a tendency to “break out” as they develop in size. A safety issue is created through this type of pruning.
- (c) Topping cuts are more prone to decay forming at the wound site This may reduce the health, stability and longevity of the tree.
- (d) Pollarding is not undertaken by MPDC.

The use of Council approved arborists with proven skills will help to ensure that all work on trees is carried out to recognised arboricultural standards that promote the health and natural form of trees.

### 2.1.3 Tree Removal

#### Objective 2.1.3.2

To ensure that consistent criteria are applied when considering the removal of Council trees for the purposes of Council initiated works.

#### Policy 2.1.3.2 (a)

In general, trees will only be removed if pruning or other remedial work is not practically possible for one or more of the following reasons of the following reasons:

Where the tree:

- Is dead, dying, diseased, decayed or disfigured with no realistic chance of recovery.
- Presents an immediate or potential danger to people or property, or is shown to be potentially a severe health or safety risk to neighbouring residents as identified by the ISA Tree Hazard Evaluation Method.
- Is causing uncontrollable structural damage to any street or utility service and remedial work to prevent further damage is impractical or greater than the value of the tree.
- Is encroaching into the carriageway in such a way that visibility is reduced or clearly causing a significant hazard and remedial work cannot mitigate the hazard without severely disfiguring or otherwise compromising the health or aesthetic qualities of the tree.
- Is inhibiting the proper management or maintenance of the reserve or other Council land
- Is inhibiting the growth, development or health of other trees of greater value.
- Is deemed to be of low amenity value and is poorly sited or requires unduly high maintenance (such as in a location which conflicts with services).
- Is unsustainable i.e. is unsuitable for the site due to its long term potential to cause problems or the inappropriateness of the species in relation to the site.
- Is recognised potential. As a species with high weed dispersion was planted for revenue producing purposes, and is, as a result, being harvested.

#### Explanation

The following are exceptions to Policy 2.1.3.2(a):

- Trees identified in a reserve management plan for retention, as they represent an integral part of the reserve.
- Trees protected by a statutory mechanism e.g. trees protected as Notable or Amenity Trees in the District Plan.
- Where Council can demonstrate, using approved evaluation methods (STEM), that the benefit to community well-being of the tree removal outweighs the benefit of retaining the tree on site (see Policy 2.1.3.3(c) and Section 2.7).

#### Policy 2.1.3.2 (b)

Council will notify affected parties and immediate neighbours prior to the removal of trees assessed as being 'valuable'<sup>2</sup>. The extent of notification and consultation will be proportionate to the level of public use and interest in the tree(s) at issue.

Exceptions to this policy are trees that are assessed as being immediately hazardous or unsustainable (see Policy 2.1.3.1(g)). Such trees may be removed without consultation.

#### Policy 2.1.3.2 (c)

The excluded species of road reserve tree listed in Appendix 1 may be removed without consultation, with the exceptions of specific trees that have been assessed as 'valuable' and noted in the Council inventory of sustainable road reserve trees.

Tree species identified as plant pests (nationally or regionally) will generally not be evaluated as 'valuable'.

#### Policy 2.1.3.2 (d)

Where capital works involving endemic tree maintenance or removal are proposed that could significantly affect the integrity of the landscape, the Council will inform mana whenua and invite them to provide comment within a specified time period. A formal consultation process is not required, however the Council will, at a minimum, communicate the proposed works by email or letter with an invitation to respond by a specified date

(Refer to 2.7 Consultation and Dispute Resolution)

(see Policy 2.7.2.2).

<sup>2</sup>A 'valuable' tree is a tree identified, through RNZIH assessment using established criteria, as having:

- Long term life expectancy of >30 years; and
- A significant role in the locality setting, which includes its contribution to amenity and ecological values.

### Objective 2.1.3.3

To ensure that consistent criteria are applied when considering the removal of Council trees in response to a request for service from a member of the public or Council.

#### Policy 2.1.3.3 (a)

Requests for tree works will only be considered after consultation, the level of which will be commensurate with the level of significance of the tree and landscape (see Section 2.7: Consultation and Dispute Resolution). Requested tree removals involving previously consulted design tree plantings will require a full public consultation process involving the wider community.

#### Policy 2.1.3.3 (b)

The initial response by Council to a request for service from a property owner or Council staff concerning tree related problems, such as loss of views, loss of sunlight, or excessive leaf litter, will be to evaluate and attempt to resolve the problem prior to considering tree removal. Examples could include the careful placement of new trees, the ongoing maintenance/pruning of trees and the removal of secondary trees. All works will be according to accepted arboricultural practice.

#### Policy 2.1.3.3 (c)

Where a tree or treescape that has been specifically planted by Council for amenity or other value exists prior to the transfer of ownership of an adjoining property, there is no requirement on Council to either remove or prunes the tree(s) for views or shade on request. The tree(s) is defined as a pre-existing condition before the most recent landowner's purchase of the property. This does not, however, preclude Council from working with applicants to try to seek resolution of their tree-related issues, regardless of when the tree was planted.

#### Policy 2.1.3.3 (d)

In response to requests for service:

- Council will only consider carrying out tree removal (or pruning work that exceeds regular maintenance requirements), where the applicant can clearly demonstrate that the adverse effects of the tree on the applicant's reasonable enjoyment of their land outweighs the benefits of the tree to other residents and to the wider community.
- Decisions on these matters will be made by the authorised Council officer or, if a decision by the officer is appealed, by the MPDC (See section 2.7: Consultation and Dispute Resolution).( Figure 2 Flow Chart as below)

## Flow Chart for Assessing Applications – Community Facilities

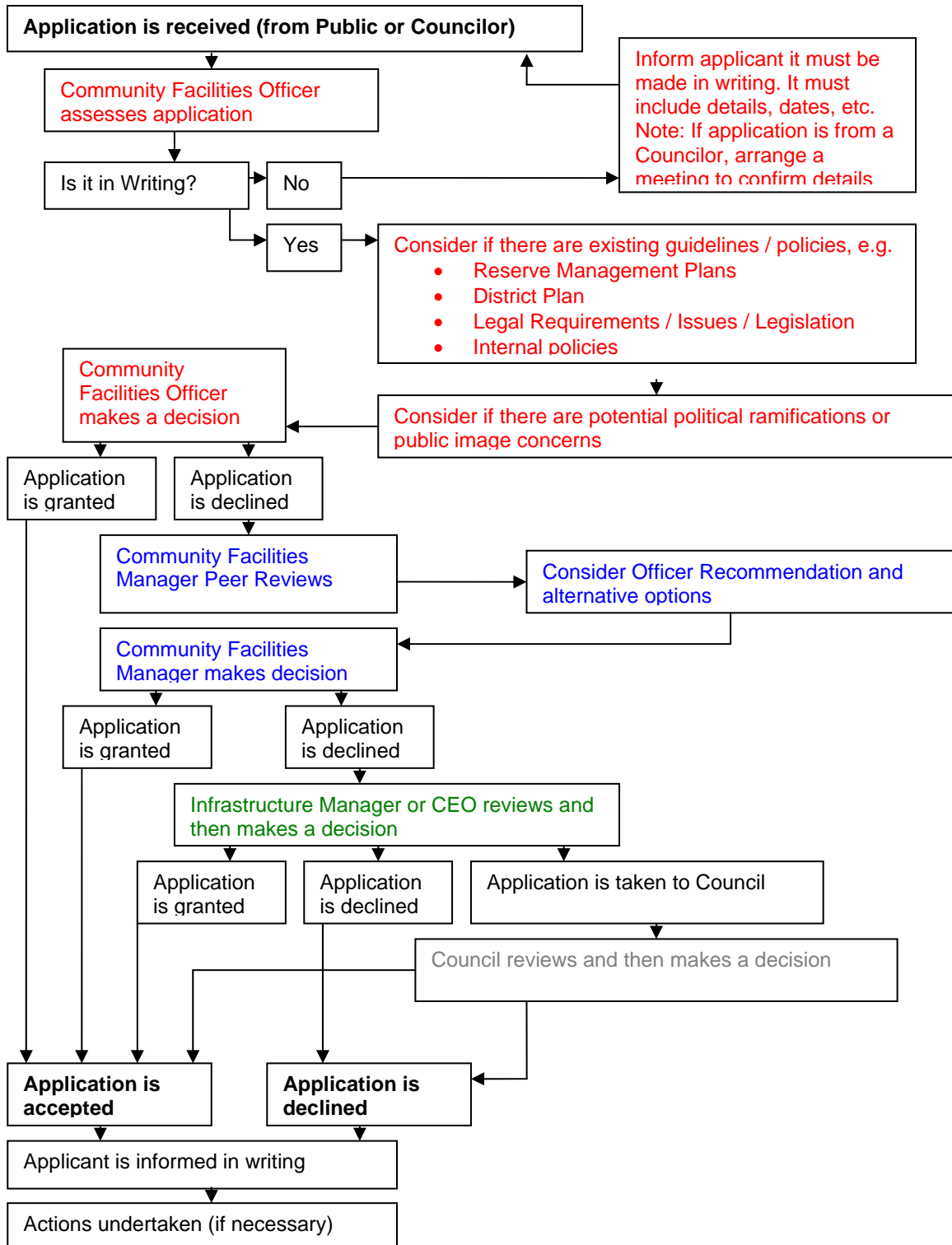

The following matters will be considered when assessing a request for tree removal (or pruning work that exceeds regular maintenance requirements):

1. The interests of the public in the maintenance of an aesthetically pleasing environment,
2. The desirability of conserving public reserves containing trees,
3. The value of the tree as a public amenity, including shade contribution.
4. The historical, cultural or scientific significance (if any) of the tree<sup>3</sup>,
5. The botanical significance of the tree,
6. The contribution of the tree to the ecology of the area, including significance as habitat for native fauna,
7. Whether the tree or treescape contributes to a landscape of regional or national significance and/or a landscape designed with public consultation,
8. The contribution of the tree(s) to the medium to long term vision of a reserve management plan or streetscape, and
9. Whether the requested works constitute good arboricultural practice, and
10. The impact of the tree (positive or negative), at that location on adjoining properties, including impact on amenity values.

<sup>3</sup> Bullets 1 – 4 are considerations with regard to trimming or removal of trees under Section 129C (6) (a) to (d) of the Property Law Act (1952)

#### **Policy 2.1.3.3 (e)**

The process of applying for removal of a healthy and sustainable tree on public land is a user-pays process. The following are criteria for assessing whether an applicant should pay for the removal of a tree. The applicant will be required to pay for tree removal in consideration of the following criteria, the level of contribution to be decided on a case-by-case basis: As per Flow Chart for Assessing Applications – Community Facilities (2.1.3.3.(d) )

- The tree is healthy and is not presenting any immediate danger to people, property or services.
- The tree does not meet other criteria outlined in Policy 2.1.2.2(a) for tree removal.
- The Council would not have scheduled the removal of this tree as part of its works without the application.
- The Council is able to demonstrate that the planting and maintenance of the tree has been appropriate.
- The tree was a pre-existing amenity at the time the property was purchased and/or the building(s) put onto the site.
- The removal of the tree benefits one or a few individuals and not the larger public.

#### **Policy 2.1.3.3 (f)**

Requests for trees to be significantly altered or removed, to accommodate specialist activities, such as building removal activities, will be assessed against the tree modification/removal criteria outlined in Policy 2.1.3.3(d). In general, a tree modification or removal will not be approved where it will compromise the landscape character of the treescape. Costs for any work carried out beyond normal maintenance to accommodate such activities will be recovered from the specialist user. This will include the cost of tree replacement and initial maintenance.

#### **Policy 2.1.3.3 (g)**

“Trade offs” that provide for long-term quality replacement trees at the expense of more short term or lower value trees are to be encouraged, where such action will resolve tree related issues. Trade offs may include replacement trees elsewhere on the site or on a different site, at the agreement of the MPDC authorised officer.

#### **Policy 2.1.3.3 (h)**

Council will record all requests for tree removal/ management on the requesting property file

#### **Policy 2.1.3.3 (i)**

Council will maintain a listing of all tree removal requests and officer recommendation outcomes

## Explanation

Council staff regularly receive requests from the public to remove trees due to perceived nuisance created by trees. As far as practicably possible, acceptable arboricultural pruning work may be carried out to mitigate the loss of views, shade and leaf litter experienced by adjoining property owners, provided that the health and value of the tree is not compromised.

In managing its tree assets on public lands, the Council takes a “good neighbour” approach. At the same time, Council has the additional responsibility of conducting its affairs to promote the well-being of all of the people in the district. To this end, the Council seeks a reasonable approach to tree management that effectively balances the interests of individual landowners with those of the wider community. This is not always a straightforward task and the policies in this document aim to provide a transparent and consistent guide to planning and decision making on tree related issues.

In general, if an individual makes a request to prune or remove a healthy tree that has been planted with previous consultation, the Council will work with the applicant and the community to determine measures, within the provisions of the District Tree Strategy, to alleviate the matter. If not satisfied with the Council’s decision on a tree matter, the applicant has recourse to pursue the matter through a dispute hearing (see Section 2.7: Consultation and Dispute Resolution).

The Council is less inclined to act on requests for tree removal to provide views where a treescape is already established at the time the property is purchased. That is because the treescape was a ‘pre-existing condition’ at the time of purchasing the property. In particular, the Council will not be required to act on requests for modification to treescapes that have been developed with public consultation.

#### Objective 2.1.3.4

To ensure best use of timber and other materials resulting from tree removal.

#### Policy 2.1.3.4 (a)

Council will consider making timber from fallen trees available to manawhenua, general public and/or local craftsmen on a case by case basis. Factors for consideration include the type and size of tree, its location and ease of removal, and the ecological benefits of leaving the materials to decompose onsite.

That all authorised wood to be removed from Council land shall be done in accordance with Health and Safety Act 2002 and in accordance with MPDC RMP 2009 2.25 Sect10 -17

Manawhenua are the iwi or hapu having customary authority over the area where the endemic tree is located.



## *2.1.4 Interference with Properties and Services*

### **Objective 2.1.4.1**

To maintain Council trees so as to avoid potential damage to, or interference with, property and services<sup>5</sup>.

#### **Policy 2.1.4.1 (a)**

Future plantings will be undertaken in consideration of the proximity to, and likely effect of, trees on above or below-ground infrastructure, consistent with urban design requirements.

#### **Policy 2.1.4.1 (b)**

When notified of damage caused by a public tree to property or services, practical steps will be taken to confirm and mitigate those effects.

#### **Policy 2.1.4.1 (c)**

Where Council trees are overhanging private property, appropriate pruning will be carried out by the Council to remove the encroachment, as far as practicably possible.

#### **Policy 2.1.4.1 (d)**

Trees on arterial routes shall be pruned or removed to provide adequate visibility where they impede or obstruct access for pedestrian and vehicular traffic.

#### **Policy 2.1.4.1 (e)**

All reasonable effort will be taken to clear street lights and reserve lights and minimise any reduction in light penetration resulting from obstruction by trees.

Where trees are obstructing a street light and accepted arboricultural practices, such as pruning, cannot be used to resolve the problem, the Council will investigate options to maintain safety standards, such as relocating the street light or the tree or installing a new light, or removing the tree.

#### **Policy 2.1.4.1 (f)**

A programme will be initiated to ensure that tree growth is maintained away from transmission lines and electrical assets, in accordance with the requirements of the Approved Code Of Practice For Safety And Health In Tree Work, Part 2: Maintenance Of Trees Around Power Lines (Department of Labour) and/or the Electricity (Hazards from Trees) Regulations 2003.

<sup>5</sup>Note: Depending on available funding, Council will also maintain Notable Trees (identified in the District Plan) on private lands so as to avoid potential threat to life, property or services. However, regular maintenance of protected trees is the responsibility of the landowner

#### **Policy 2.1.4.1 (g)**

Any clearance or maintenance around aboveground electrical services, such as transmission lines, will only be conducted by the principle contractor for the power provider, and will be undertaken on a case-by-case cost-negotiated basis.

#### **Policy 2.1.4.1 (h)**

The Council will remove or commission the removal of unsustainable trees (i.e. trees having potential for ongoing interference with surrounding activities, services, assets, properties and infrastructure) with appropriate consultation.

#### **Policy 2.1.4.1 (i)**

Trees that compromise and/or conflict with radio and telecommunications operations will be pruned and/or removed as deemed necessary to maintain safety and essential services.

#### **Policy 2.1.4.1 (j)**

Council Utilities Departments are to notify Community Facilities where the upgrades will affect or impact on trees.

#### **Policy 2.1.4.1 (k)**

Utility providers to notify Council and the Community Facilities Department of all remedial and emergency works.

#### **Explanation**

These policies seek to avoid potential damage to property and services. Particularly within the street environments there will always be ongoing commitments to ensure that trees do not conflict with services such as wiring, drainage systems, footpaths, kerbing, vehicle and pedestrian movement and property security.

Trees planted beside or under power lines will be trimmed in order to comply with the safe clearance requirements of the approved Code of Practice and local power supplier. Wherever possible, directional pruning methods will be used to remove branches growing towards power lines and to promote growth away from the lines.

Trees considered being a safety hazard, or interfering with shipping navigation, radio and/or telecommunications facilities, or undermining a flood protection or erosion control structure will be pruned or removed as deemed necessary.

Upgrades to utilities services and their impact on trees

### *2.1.5 Wilful Damage to Council Trees*

There have been several instances in recent years of members of the public wilfully damaging Council trees, including deliberately killing trees. This type of activity is an offence under a number of New Zealand statutes and is prohibited under 3.2.2 of the Public Amenities part of the MPDC Consolidated Bylaw 2008. It also represents a wasteful squandering of public resources. The Council will respond strongly to any incidence of wilful damage to Council trees.

#### **Objective 2.1.5.1**

To respond in a consistent manner to the wilful damage of Council trees, in order to deter future offences of this nature and to take appropriate action according to New Zealand law.

#### **Policy 2.1.5.1 (a)**

Council will assess and, where appropriate, replace trees on Council lands that have been wilfully killed or damaged.

#### **Policy 2.1.5.1 (b)**

Council will refer incidents of wilful tree damage or death to the police, who will investigate with the intention of prosecution where sufficient evidence suggests that a person or persons have committed this offence.

#### **Policy 2.1.5.1 (c)**

Council will use such incentives, to bring the successful prosecution of individuals, as is deemed necessary, for information leading to the arrest of individuals responsible for damage to Council trees.

#### **Policy 2.1.5.1 (d)**

Council will bring the issue of significant vandalism to the attention of the public and to explain the Council response.

#### **Policy 2.1.5.1 (e)**

Persons found guilty of wilfully damaging Council trees will be responsible for the cost of removal of the dead trees as well a tree replacement.

#### **Policy 2.1.5.1 (f)**

No person may remove or plant any tree on any Council roadside berm or reserve without the full permission of the Council

#### **Policy 2.1.5.1 (g)**

If a tree that has been killed or is required to be removed because of wilful damage and was originally planted following public consultation, the Council will not have to consult again before undertaking replacement planting. (Refer to Appendix 2, 5, 6, 7)

### Explanation

The Council is committed to taking appropriate action, legal or otherwise, in response to wilful damage or destruction of Council trees. The following laws pertain to this offence:

- Under Section 11 of the Summary Offences Act (1981), a person intentionally damaging property is liable to imprisonment or a fine.
- Section 175 of the Local Government Act (2002) provides local authorities with the power to 'recover for damage by wilful or negligent behaviour.'
- It is an offence under Section 94(1) (f) of the Reserves Act (1977) to remove or wilfully damage any or any part of any tree, shrub, fern, and plant on any reserve. Damage to property belonging to the Council placed or erected on any public place, including trees, is prohibited under clause 3 Public Amenities Bylaw of the MPDC Consolidated Bylaw 2008

## 2.2 Street Tree Management

This section contains policies relating to planting and maintenance of street trees, specifically, the formal planting of streetscapes on road reserves. These plantings are undertaken to enhance the amenity value of residential areas and public consultation is required.

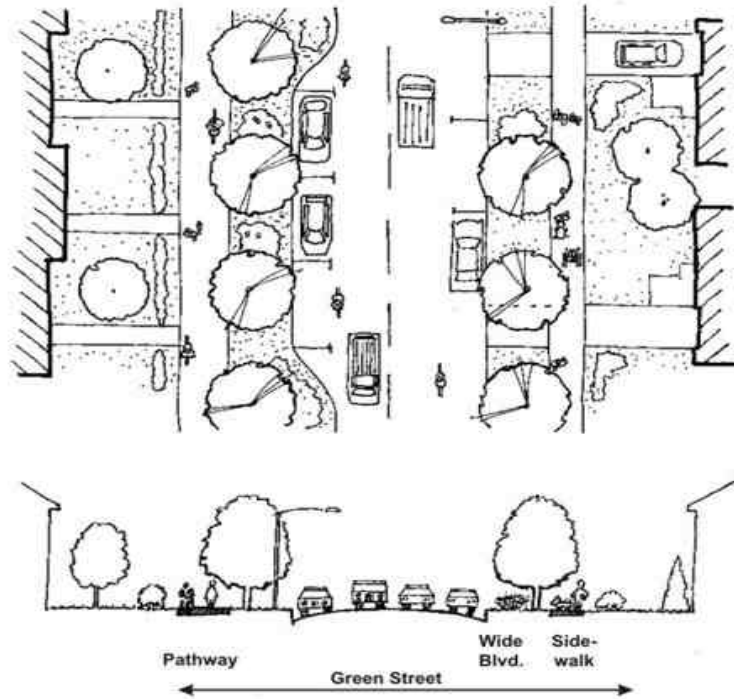

### Objective 2.2.1

To enhance the streetscape within the urban and rural district, through the planting of trees.

### Policy 2.2.1.1

Tree plantings will be targeted to both in the urban and rural areas where:

- There is sufficient support by residents,
- There is sufficient space to accommodate root zone development (the minimum requirement is 1.5 metres wide),
- Street trees are unlikely to cause significant long term management problems (such as potential conflict with overhead wires, underground services, traffic visibility) and
- Trees will enhance the quality of the streetscape.
- That appropriate root guard systems may be required to protect services and roading/ footpaths. Each application will be judged on a case by case basis. (Refer 2.7 Consultation)

#### **Policy 2.2.1.2**

The actual placement and selection of individual street trees will be based on the following matters:

- The overall design of the street planting, in new subdivisions, rural, residential and industrial areas and link roads.
- The proximity to and likely effect on overhead transmission lines and street lighting,
- The proximity to and likely effect on underground services,
- The effect on vehicular and pedestrian access and sight visibility,
- The possibility of alternative roading plans, such as road widening and intersection improvements, and
- Existing or planned structures or 'street furniture on the site'.

#### **Policy 2.2.1.3**

Consultation with affected parties, including local residents and property owners will be undertaken before any formal street tree planting is undertaken. The level of consultation will be commensurate with the size of the works and the level of public interest in the area. Wider public consultation will be undertaken in commercial areas and/or areas of high public use, as necessary. (Refer to 2.1.1.6)

Consideration will be given to written requests from residents not to have a street tree outside their property, and a decision will be based on how critical the tree is to the overall design for the street.

#### **Policy 2.2.1.3**

Where street planting is impractical or inappropriate, the Council will encourage residents to plant appropriate trees on private land adjoining the street frontage by providing suitable tree specimens and advice. The responsibility for the maintenance of these trees remains with the landowner.

#### **Policy 2.2.1.4**

The quality and effectiveness of street trees plantings will be regularly reviewed, by way of programmed inspections measured against standards in technical guidelines in Part 2 of the District Tree Strategy and the Code of Landscape Design and Practice.

#### **Policy 2.2.1.5**

The criteria listed in the District Tree Strategy Profile and Street Tree Selection Criteria (Appendix 3) will be used as the basis for tree selection for street tree planting.

#### Policy 2.2.1.6

Unauthorised planting of trees by residents on street berms, in both urban and rural settings, are not permitted and this activity will be actively discouraged. Council may remove the trees that are planted, without reimbursement for those trees where they are planted without Council authorisation<sup>6</sup>



#### Street Tree planting on berms

##### Explanation

While street trees can significantly contribute to the improvement of the urban and rural environment and enhance residential development they are also the cause of regular public opposition and may be expensive to maintain. It is important to ensure that there is sufficient local support prior to undertaking new plantings and then to ensure that trees are chosen and placed where there is a high chance of success with limited long term management problems i.e. that all trees planted on Council administered land are sustainable.

The current trend of rationalising the removal of low value high maintenance trees and redirecting funding to developing high value low maintenance plantings will be a priority.

Council will also seek to enhance streetscapes through encouraging private landowners to plant trees on their properties and by liaising with developers to create improved planting opportunities through alternative street designs (see [Part Four. Appendix 8: Planning and Management of Trees, treescapes and significant other vegetation during Subdivision and other types of development](#)).

Public Amenities Bylaw 2008 Section 3 prohibits the disturbance, removal or altering of the surface of any public place, including the planting of any vegetation, plant or shrub, without the prior permission of the Council and in accordance with such conditions as the Council may impose.

## 2.3 Management of Tree Collections

The Matamata-Piako District has a strong heritage of horticultural excellence and the district supports a number of parks and plant collections, including tree collections as a result of the skill, foresight and generosity of early residents, built on by subsequent decades of skilful management by talented individuals.

Tree collections are groups of trees formally planted and managed at a site to enhance the diversity and value of the district. Collections may be single species, such as the Oak plantation in Hetana Street Reserve, or multiple species, such as the collection in Centennial Drive Matamata.

They may be composed of indigenous or exotic species or a mixture of species. Tree collections are a dynamic resource. Their management involves ongoing maintenance, replacement, removal and renewal. All decisions related to the management of tree collections are based on sound arboricultural principles and best practices.



**Autumn colour in Parks and Reserves**

### **Objective 2.3.1**

To continue to develop collections of valuable trees and botanical specimens throughout the Matamata-Piako District that build on a local heritage of horticultural expertise and establishes the district as a centre of arboricultural excellence.

### **Policy 2.3.1.1**

The existing botanical diversity resulting from the mix of native and exotic trees will be preserved and enhanced for both local and visitor interest.

#### Policy 2.3.1.2

Council will develop a range of types of tree collection, including single species and mixed species collections and a variety of themes suited to the district and its ecology and heritage.

#### Policy 2.3.1.3

Tree collections will be developed, with an emphasis on factors such as:

- Longevity
- Diversity
- Heritage value (natural and built)
- Local character (natural and built)
- Low maintenance
- Wildlife habitat

#### Policy 2.3.1.4

Tree collections may be established on reserves or areas of reserves that are difficult to manage through grazing or mowing.

#### Explanation

Parks and reserves should be seen as an extension to our tree collections, broadening the vegetation gene pool and allowing a wider use and monitoring of new species. There are already developed tree collections and the opportunity exists to extend these further.

#### Objective 2.3.2

To maintain and enhance existing tree collections for the amenity, aesthetic, enjoyment, environmental, educational and economic benefit of the people of Matamata-Piako District, now and into the future.

#### Policy 2.3.2.1

Tree collections will be managed to be aesthetically pleasing as well as for their functional and botanical values.

#### Policy 2.3.2.2

Allow for appropriate arboricultural treatment (e.g. thinning or removal) of those specimens that exhibit obvious structural faults and/or are overcrowding a plantation, in order to promote the process of natural regeneration and ensure the remaining vegetation have a long term future.

#### Policy 2.3.2.3

Control adventitious weed and tree species, with priority on those that compromise the integrity of the collection or suppress the natural regeneration process.

#### Policy 2.3.2.4

Control animal pests, particularly rats and possums, to maintain pest numbers at low levels and allow natural regeneration of seedlings.

#### Policy 2.3.2.5

Minimise the potential for adverse effects arising from surrounding environmental changes, such as loss of shelter, alterations to drainage systems and the impact of subdivision and development.

#### Policy 2.3.2.6

Increase public awareness about the Council tree collections through the use of brochures and posters. (Refer to 2.8 Education and promotion)

#### Policy 2.3.2.7

Reduce damage to vegetation by increasing public awareness and encouraging neighbourhood policing and protection of collections through improved interpretation signage and publicity. (Refer 2.8 Education and promotion)

#### Objective 2.3.3

To actively manage all district tree collections according to contemporary arboricultural practice and to a standard befitting a centre of arboricultural excellence.

#### Policy 2.3.3.1

Latest technologies will be used to track and manage district collections.

- Including developing and maintaining a database on district tree assets.
- Recording associated species lists.

#### Policy 2.3.3.2

Ensure that skilled people are on staff to manage tree collections to a standard appropriate to a centre of arboricultural excellence. (Refer to District Tree maintenance Contract 1698)

#### Explanation

The tree collections in the Matamata-Piako District are a extremely valuable asset and make an important contribution to community prestige and enjoyment. A long term sustainable management approach needs to be applied to ensure that the quality and value of tree collections continues to be maintained and enhanced in the district and to increase environmental and community value for many generations to come.

Numerous opportunities exist to build on existing collections. Currently the Council has some reserves that are maintained by grazing or irregular mowing. Many are difficult to manage this way and those suited to planting may be scheduled for conversion to urban tree collections.

## 2.4 Council Owned Management of Bush Remnants

Bush remnants are vestiges of the tracts of contiguous indigenous (native) vegetation that once occurred throughout the district. The species composition in these remnants primarily reflects the species typical of the Kaimai and Waikato Ecological Regions. In general, indigenous vegetation can be defined as “flora occurring naturally in New Zealand or belonging naturally to New Zealand”. Bush remnants may exist as stand alone entities or co-exist within an area of cultivated landscape.

Bush remnants have a distinct ecology that requires management that is different to cultivated landscapes. The essence of remnants is that they reflect an unmanaged stand, with associated ecosystem structures, functions and interactions. A bush remnant is not only trees; it is the undergrowth, the epiphytes, the ground cover, the water flow through the system and the wildlife that use these areas as habitat. For this reason, the focus of management within bush remnants is to minimise intervention and to let natural processes take their course as long as the structural and functional integrity of the remnant is not at risk due to pest plants or animals or other external threats.

Bush remnants may seem untidy to people accustomed to cultivated landscapes. However, the random growth that typifies remnants is part of the structural diversity that contributes to the overall healthy functioning of the ecosystem.

The District Tree Strategy does not apply to Significant Natural Areas listed in the District Plan, since their management is addressed through District Plan rules. Significant Natural Areas (SNAs) are identified based on representativeness, diversity and pattern, rarity and special features, naturalness, ecological viability, size and shape, buffering and surrounding landscape, fragility and threat, fauna values, management requirements and the criteria outlined in the Regional Policy Statement.

The District Tree Strategy does apply to all other patches of indigenous vegetation on public lands, including reserves established under Sections 230 or 236 of the Resource Management Act 1991 (RMA). Although these ecosystems do not meet the criteria for ‘significance’ under the RMA 1991, they are still important for their intrinsic value and because they provide wildlife habitat and wildlife corridors, help protect water quality and quantity and contribute to soil conservation, landscape and amenity values.

A large number of bush remnants in urban areas in the district are within or adjacent to riparian areas (inhabiting or along side a river system). Riparian vegetation requires specific management approaches. It is proposed that Council staff look at the process of developing a set of policies for the management of riparian ecosystems, which will complement the policy on bush remnants. The Regional Fresh Water Plan for Waikato sets out standards and conditions regarding the management of wetlands. These will be considered in any Council policy on management of riparian ecosystems. (Refer to the District Plan)

### **District Plan policies pertaining to management of indigenous vegetation.**

The following objectives, policies and methods of implementation in the MPDC District Plan support the sustainable management of bush remnants.

District Plan Objective 1. Landscape character, 2. Natural Environment 3.1.2 O1-O2: To sustainably protect manage, and enhance where practical, indigenous vegetation and habitats.

District Plan Policy 3.1.2 P1: Land use, development and subdivision should not result in adverse effects on, and should enhance where practical, the quality and intrinsic values of areas of indigenous vegetation and habitats.

Additionally, Policies 3.1.2 2. Natural environment P1- P3 of the District Plan pertaining to preventing adverse effects of subdivision, use and development on the natural character of wetlands, lakes, and rivers and their margins.



#### **Objective 2.4.1**

To ensure that the natural landscape character of the district is maintained and enhanced through the appropriate planting, enhancement and maintenance of bush remnants.

#### **Policy 2.4.1.1**

A database will be developed and maintained of bush remnants on Council lands. This database will track the area, ecological value, and condition and management status of each bush remnant. It will also include available information on fauna using the area.

#### **Policy 2.4.1.2**

To the extent possible, bush remnants shall be managed to maintain a 'natural state'. Maintenance activities that alter the natural state of the vegetation<sup>7</sup>, such as pruning, will not occur except to address issues of safety and tree health. Modification will be limited to clearing for trails, where appropriate and managing boundary encroachment.

<sup>7</sup>Including trees, undergrowth and ground cover

**Policy 2.4.1.3**

Ensure that bush remnants on lands administered by the Council remain ecologically intact to naturally regenerate, in order to maintain the natural species diversity of indigenous vegetation typical of the Waikato area.

**Policy 2.4.1.4**

Where necessary, local pioneer species, appropriately eco-sourced, will be planted to speed up regeneration and reduce weed control.

**Policy 2.4.1.5**

Plantings of late successional vegetation within bush remnants will only use plant material that is eco-sourced from the appropriate ecological district.

**Policy 2.4.1.6**

Native species that do not naturally occur in the district will only be planted in actively managed landscapes and not in bush remnants.

**Policy 2.4.1.7**

Management of remnant vegetation within the riparian zone of wetlands and other water bodies will be consistent with the rules in the Waikato Regional Fresh Water Plan and will contribute to the sustainable management of the regionally significant wetlands listed in the Plan.

**Policy 2.4.1.8**

Adventitious weed and tree species will be controlled, with priority on species that compromise the integrity of the remnant or suppress the natural regeneration process.

**Policy 2.4.1.9**

Animal pests will be controlled to maintain acceptable levels in accordance with the "Environment Waikato Pest Strategy".

**Policy 2.4.1.10**

The Council will liaise with other government authorities (e.g. Environment Waikato Regional Council, Department of Conservation) to ensure consistency and co-operation with their plant and animal pest control programmes.

### Explanation

Council recognises the benefits of maintaining native bush remnants as an essential component of the natural landscape. It is important that the ecological value of these areas is not compromised or modified by inappropriate planting and maintenance activities.

Generally, bush remnants are self-sustaining, providing that they have the ability to regenerate naturally. However, plant and animal pests need to be controlled to ensure that the integrity of indigenous vegetation is not compromised. Environment Waikato Regional Council and Department of Conservation have well developed plant and animal pest control programmes that can help to guide appropriate strategies and priorities.

The relationships developed in the District Plan [Section 1.4 - 1.4.12](#) i.e. The Kaitiaki (Conservation) zone,



**Kaitiaki zone – conservation zones**

### Objective 2.4.2

To avoid adverse effects on the quality and intrinsic values of indigenous vegetation and habitats during land use, development and subdivision.

### Policy 2.4.2.1

Physical services, such as stormwater, roading, kerb and channelling, and carriageways, will be designed to minimise or mitigate potential adverse effects on the quality and intrinsic values of bush remnants.

#### **Policy 2.4.2.2**

The location and boundaries of bush reserves will be delineated in consideration of the long term ecological integrity of the reserve. For example, wherever possible boundaries should extend beyond the outer side of the dripline. Also, planting of appropriate species along the outer edge of a remnant can help to maintain the interior microclimate and minimise 'edge effects' (Refer to Glossary).

#### **Policy 2.4.2.3**

Where feasible, access will be provided to bush remnants for the purposes of ongoing Council maintenance.

#### **Policy 2.4.2.4**

The condition of bush remnants that are established as vested Council land as an outcome of subdivision will not be compromised as a result of development activities. This includes leaving the remnant in a natural state, fenced, free of rubbish, at the time of Council takeover.

#### **Policy 2.4.2.5**

The potential to develop walkway systems for education and interpretation and outdoor enjoyment of the public will be assessed on a case by case basis, in consideration of long term ecological consequences.

#### **Policy 2.4.2.6**

Provide barriers and signage, where necessary, to discourage recreational uses that have the potential to damage vulnerable bush remnant ecosystems.

#### **Policy 2.4.2.7**

Regularly maintain and upgrade fencing around Council owned bush remnants to prevent stock entry, as required.

#### **Policy 2.4.2.8**

The dumping of rubbish or refuse in bush remnants is prohibited and will be treated as an offence. This includes the dumping of green waste such as garden debris<sup>8</sup>

<sup>8</sup>Dumping of refuse and offensive matter in a public place is prohibited under Public Amenities Bylaw 2008 Section 3.3.1 of the MPDC Consolidated Bylaw 2008. Dumping on a reserve is also an offence under Section 94(1) (d) of the Reserves Act (1977).

### Explanation

- Bush remnants in urban environments are vulnerable to a variety of impacting activities. The ecological integrity of indigenous vegetation may be adversely affected as a result of alteration or modification within or adjacent to the site. Potential impacts include:
- Inappropriate use by recreationists may compromise the quality of the site, as may grazing of the under growth.
- Dumping of garden waste can result in the introduction of exotic or non-endemic plant species that compete with indigenous plants for space and nutrients.
- Developments adjacent to a bush remnant, such as subdivisions, have the potential to alter drainage patterns and disrupt the contiguity of the remnant.
- Alterations adjacent to the site that result in the removal or disturbance of boundary vegetation may introduce 'edge effects' that increase light levels, increase vulnerability to wind damage, and compromise natural regeneration processes. Adverse effects on remnant vegetation can be minimised through appropriate design land use activities and by promoting respect and stewardship of these areas by members of the public

### Objective 2.4.3

To foster public interest, awareness and guardianship of bush remnants and their ecological and aesthetic benefits.

#### Policy 2.4.3.1

Reduce damage to vegetation by increasing public awareness and encouraging neighbourhood policing and protection of bush remnants. Examples of possible methods to achieve this include providing signage, interpretive walkways, and public awareness campaigns.

#### Policy 2.4.3.2

Promote community awareness about the values of, threats to and protection of areas of indigenous vegetation and habitats. This includes informing the public about the ecological values of bush remnants and the contribution of all parts of the ecosystem, including trees and undergrowth, to healthy ecosystem function. (Refer to 2.8 Education and Promotion)

#### Policy 2.4.3.3

Assist community-based groups involved with pest control or restoration of bush remnants and riparian areas, consistent with the Council's volunteer policy and relevant health and safety legislation.

#### Policy 2.4.3.4

Provide information and advice about mechanisms to maintain and enhance areas of indigenous vegetation and habitats.

### Explanation

Increasing public awareness about the ecological and aesthetic benefits of bush remnants is intended to create a sense of appreciation and stewardship of these areas.

The desired outcomes are twofold:

- To maintain support for retention of bush remnants by the Council; and

- To reduce the incidence of vandalism, rubbish dumping, and other damaging behaviour.

Council staff are able to work with volunteer restoration groups within the context of available funding allocations and the ability to supervise volunteer activities, as outlined in the Council's Use of Volunteers Policy. Any activities also need to comply with the Health and Safety in Employment Act 2002.

## 2.5 Commemorative Trees

Trees have been planted on public lands throughout the district to commemorate specific people and events. Commemorative plantings are often undertaken in the memory of someone that has recently passed away. Visiting dignitaries may plant a tree to provide a lasting memento of their visit. Trees have also been donated by groups and organisations as a contribution to the district. Council regularly receives requests for new plantings. Commemorative trees hold a special significance to people and their management is, therefore, particularly sensitive. In addition to managing the physical needs of the tree, the history of the tree also needs to be recorded and preserved.

Once planted, commemorative trees become a Council asset and are maintained to Council standards. As with all Council managed trees, plantings need to be appropriate to the site and area, maintenance must be according to best arboricultural practice, and tree removals may be necessary on occasion. All of these matters will be dealt with according to the District Tree Strategy.

RMP Sec 12.0 P 72

RMP Sec 13.0 Schedule H P 186



*Liquidambar*

### **Objective 2.5.1**

To identify, map and maintain existing donated and commemorative trees, recognising their special significance.

#### **Policy 2.5.1.1**

An up-to-date record of commemorative trees and plaques in the District will be maintained. The purpose of the planting and sponsoring individuals or groups will be included in the record.

#### **Policy 2.5.1.2**

Commemorative trees will be maintained to Council tree standards.

#### **Policy 2.5.1.3**

Relocation or removal of a commemorative tree may be undertaken where necessary, based on an assessment of the value of the tree, the ability to relocate or replace to another site, and the costs and benefits to community well-being of various tree management options.

#### **Policy 2.5.1.4**

Commemorative trees that have died or need to be removed may be replaced, although a more suitable species and/or site may be selected for the replacement tree. Consultation with original donor or donor's family will be undertaken where possible.

#### **Policy 2.5.1.5**

The sponsors of a commemorative planting will be informed if a tree(s) needs to be removed or relocated.

#### **Policy 2.5.1.6**

Council will not place plaques on commemorative trees.

### **Objective 2.5.2**

To strategically plan and manage the location and species of future commemorative plantings.

#### **Policy 2.5.2.1**

Prepare a strategy for future commemorative plantings,

#### **Policy 2.5.2.2**

Identify specific locations for future planting

#### **Policy 2.5.2.3**

Develop a set of criteria for site and species choice.

### Explanation

Commemorative plantings are a special category of the Council tree in that they have a special meaning for some individuals and their history is important. Policies on future plantings cannot be developed until a strategy is completed to address issues such as:

- Location of future plantings (e.g., commemorative tree parks that could include commemorative tree parks for the interment of ashes).
- Species that should be planted.
- Criteria for acceptance of donated/commemorative trees.
- Process for seeking permission to plant a commemorative tree.
- Processes relating to tree death, removal or replacement.
- How to cover costs for planting and long-term maintenance.

Council has a policy of not placing plaques on commemorative trees because they are a challenge to manage and they can be unsightly, interrupting the natural line of the tree.

## 2.6 Planning and Management of Trees during Subdivision and other Types of Development

The District Tree Strategy only applies to trees, treescapes and significant vegetation on land administered by the Matamata-Piako District Council, however can be utilised as a guide for other areas.

- A development, within the district, would include land that vests as Council land on plan deposit, such as road reserves, footpaths, and contribution land for public use as a reserve.
- It is important to consider the landscape implications for this land early in the design and planning process i.e. before the application is lodged.

Trees, treescapes and significant vegetation need to be considered early in the development process for the following reasons:

- To ensure that the planning of the development adequately considers the needs of existing and future trees, treescapes and significant vegetation.
- To ensure that existing and future trees, treescapes and significant vegetation will not conflict with the development i.e. above and below ground structures and other infrastructure, and
- To identify and offset potential future conflicts concerning views, shade, leaf litter and other issues related to diminished amenity values.

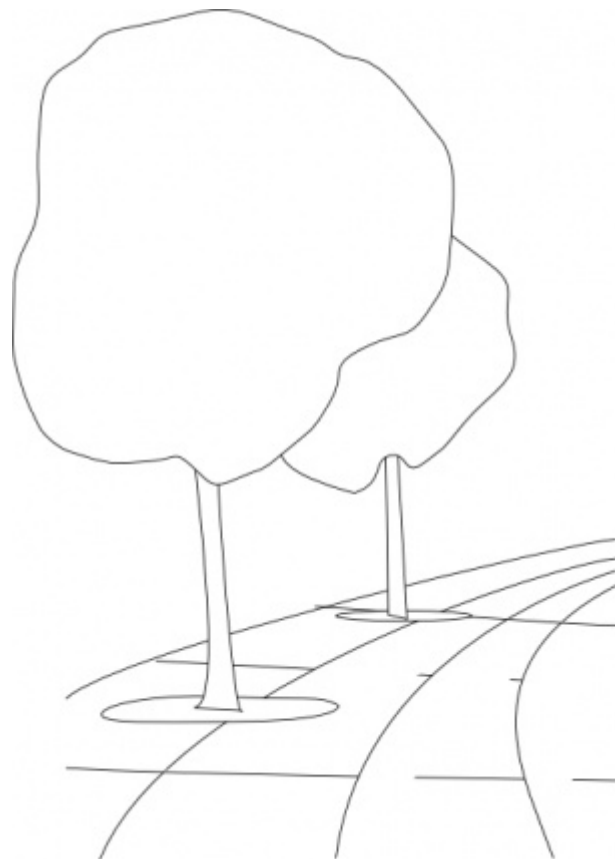

**District Plan provisions related to trees and development:**

The current Matamata-Piako **District Plan** contains regulatory and non-regulatory provisions for the protection and maintenance of trees, treescapes and significant vegetation on both public and private land. (Part A Section 3 Environment 3.1, 3.4, 3.9 Part B 1 general provisions, 6 Suidivision, 10 Natural Heritage and Environment.

The subdivision consent process under the Resource Management Act (1991) provides opportunity to assess vegetation on development sites and to attempt to retain or work around trees, treescapes and significant vegetation identified to be of significance. In many cases an assessment will identify vegetation of little significance that may be removed in exchange for retention of any significant trees, treescapes and significant vegetation on the site or mitigation by replacement trees. The intention is not to place unrealistic expectations on the developer to retain vegetation of little value, but to provide assistance on how best to integrate the urban design and any significant vegetation on the site.

**Objective 2.6.1**

To ensure appropriate consideration of, and planning for, trees and treescapes during the design and consent process for resource consents

**Policy 2.6.1.1**

Council officers will work with resource consent applicants to identify opportunities to plant or retain trees, treescapes and significant vegetation during the design and consent process.

Considerations will include:

- Centre islands or median strips wide enough for planting (minimum 2m and as appropriate to the species planted).
- Wider grass berms. (minimum of 1.5 m if tree landscaping proposed).
- The inclusion of root barriers
- The inclusion of rain garden concepts within new development or where existing developments are being altered. Recommendation for plants in this concept are tabled in Appendix12. (Refer to Development manual)



**The use of trees within residential settings**

Design layout to include the protection and enhancement of significant trees, treescapes and significant vegetation with the development

The use of “set backs”, all urban areas to provide space for tree canopies to develop.

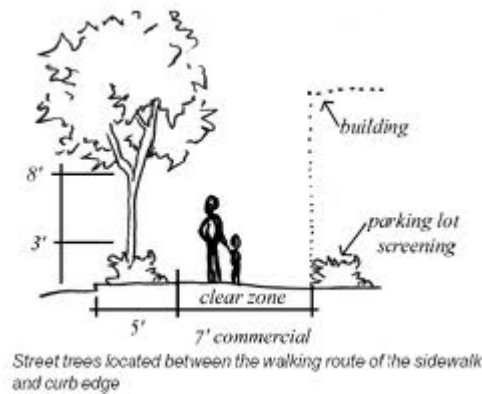

Maintaining road safety and activity clearance, including:

- Minimum 2 m from vehicle access ways (e.g., driveways),
- Minimum 1.5 m from underground services, and
- Minimum 5m from overhead services and/or compliance with the Electricity (Hazards from Trees) Regulations 2003.

#### Policy 2.6.1.2

In general, tree, treescapes and significant vegetation will be sought for developments that create new roads or wherever new public land is created as an outcome of the resource consent. Also where re-development occurs.

#### Policy 2.6.1.3

Community Facilities Staff or an appointed agent will assess development proposals, upon requests from MPDC Planning and offer advice on opportunities to plant new trees, treescapes and significant vegetation or to maintain existing trees, treescapes and significant vegetation prior to formalising the development concept.

NOTE: This service may incur a cost

#### Policy 2.6.1.4

Council will work together with the community to promote the long term health of existing, future and protected trees, treescapes and significant vegetation within Council and private lands as an outcome of development design and planning. This includes recognition of the importance of root zones to tree health and the need to manage for tree health below-ground as well as above-ground.

#### **Policy 2.6.1.5**

Council will work with developers and planners to ensure that existing and future trees, land or trees that are administered by the Council are included in development designs in consideration of their proximity to, and likely effect on, above or below ground infrastructure as well as ecological implications.

#### **Policy 2.6.1.6**

Council will provide incentives to encourage developers to adopt the Code of Landscape Design and Practice. These could include:

- Providing recognition, in the form of awards and other publicity, for developments that meet or exceed the Code.
- Providing advice on the appropriate species to plant in the location and design.
- Promote incremental value to a development as a result of providing an attractive landscape design that includes existing and new trees. This includes providing habitat for easily recognised and popular bird species such as tui and kereru.

#### **Policy 2.6.1.7**

Council will undertake education and promotion work to increase awareness and understanding of the values and benefits of trees, treescapes and significant vegetation (as outlined in section 1.4.2), the requirements for long-term tree health, ways to incorporate trees, treescapes and significant vegetation into a development plan and plant species for street site character areas. Target audiences could include developers, surveyors and realtors.

#### **Policy 2.6.1.8**

Developers are required to assess the value of existing mature trees, treescapes and significant vegetation onsite and to design their development to protect and enhance those features.

#### **Policy 2.6.1.9**

Developers are required to incorporate significant trees, treescapes and significant vegetation within their development design to ensure that shade or views do not become an issue with subsequent landowners

## Explanation

The MPDC Code of Landscape Design and Practice (CLDP), and Urban Design Principles once completed, will set the standard for developments in the district. The CLDP will provide technical guidelines on appropriate tree and site selection and preferred infrastructure design to ensure attractive and functional landscapes over the long term.

The Urban Design Protocol found at (<http://www.mfe.govt.nz/issues/urban/design-protocol/>) identifies seven essential design qualities:

- **Context:** Seeing that buildings, places and spaces are part of the whole town or city
- **Character:** Reflecting and enhancing the distinctive character, heritage and identity of our urban environment
- **Choice:** Ensuring diversity and choice for people
- **Connections:** Enhancing how different networks link together for people
- **Creativity:** Encouraging innovative and imaginative solutions
- **Custodianship:** Ensuring design is environmentally sustainable, safe and healthy
- **Collaboration:** Communicating and sharing knowledge across sectors, professions and with communities.

One of the most effective methods of ensuring appropriate consideration of trees and treescapes during development is to increase awareness and understanding of the values and benefits of trees and the importance of the “right tree in the right place”.

The additional benefit of careful proactive planning for treescapes during developments is that future conflicts over adjacent trees, due to shade or interruption of views, can be mitigated. Also the safety of the site by the adoption of the CPTED principles (Crime Prevention Through Environmental Design)

- Territoriality – physical design is used to promote a sense of ownership, respect, responsibility and community.
- Natural surveillance – where all publically accessible places are overlooked, people can see and be seen.
- Access control – places with well defined routes, spaces and entrances that provided for convenient movement without compromising security.
- Space management - appropriate use of space, well cared for, attractive and vandal resistant facilities and buildings.
- Activity support – places where human activity is appropriate to the location.

## 2.7 Consultation and Dispute Resolution

This section covers Council's approach to consultation relating to tree management and maintenance, together with the process for handling appeals concerning decisions relating to trees on Council administered land. It outlines the mechanisms that the Council shall use to address enquiries and the process for resolving appeals.

### Objective 2.7.1

To undertake an appropriate and reasonable level of consultation with parties who may be affected by proposed tree related works.

#### Policy 2.7.1.1

Consultation with local residents and property owners will occur:

- Wherever this is appropriate, before any major street tree or reserve works is undertaken.
- In commercial areas and areas of high public impact, wider public consultation will be undertaken e.g., with business owners or with the public at large.
- In general, consultation will focus on gaining input from parties most affected by planned tree works.

Accordingly, street tree planting will primarily involve consultation with neighbours while consultations about reserve plantings will involve a wider community.

#### Policy 2.7.1.2

Consultation with local residents and property owners will be undertaken:

- Before any removal of trees assessed as 'valuable' by the Council.
- The level of consultation will be commensurate with the breadth of concern about the tree(s) and whether the trees are in a commercial areas and/or area of high public impact.

### Objective 2.7.2

To recognise and appropriately provide for the cultural and spiritual values of tangata whenua when managing the district tree resource.

#### Policy 2.7.2.1

Consideration will be given to cultural sensitivities associated with the operations of tree planting, tree maintenance and tree removal including any ground works on or adjacent to waahi tapu sites and other culturally sensitive areas identified in the District Plan or otherwise made known to the Council. This may include guidance of how work may be conducted, karakia, dispersal of trimmings and induction and access to the site.

#### Policy 2.7.2.2

In capital works involving trees plantings or proposed removals; that could significantly affect the integrity of the landscape:

- Council will inform the appropriate iwi or hapu (manawhenua); and
- Invite them to provide comment within a specified time period.

A formal consultation process is not required, however, the Council officer will, at a minimum, communicate the proposed works by letter or email with an invitation to comment by a specified date.

#### Objective 2.7.3

To ensure that enquiries, disputes, and appeals concerning trees are resolved through established processes that are consistently applied.

#### Policy 2.7.3.1

Contractors undertaking works for the Council are not authorised to directly represent the Council for public enquiries relating to trees, unless specifically delegated to do so by the appropriate asset manager.

#### Policy 2.7.3.2

A property owner can apply for the maintenance or removal of Council trees using the following process. (See Figure 2):

- (a) All external enquiries relating to Council trees will be directed to the Council Customer Services Centre.
- (b) If not satisfied with the Council response to the initial request, the applicant may make a follow-up request, in writing, to the appropriate Council manager.
- (c) The manager will review the written request and decide on an appropriate course of action, in consideration of the District Tree Strategy and other available information.
- (d) The asset manager will inform the applicant of the Council decision in writing, outlining the reasons for accepting or declining their request.

#### Policy 2.7.3.3 (a)

If the resident applicant is not satisfied with the outcome of the process outlined in Policy 2.7.3.2, they may request that the issue be elevated to Councils Infrastructure manager and/or CEO. If the applicant is still unsatisfied with the decision by the CEO, the application shall go direct to Council for consideration whose decision is final.

### Policy 2.7.3.3 (b)

Where ongoing controversy over tree management arises in an area that is not within a reserve and, therefore, is not addressed through a reserve management plan, and:

- The trees are within areas of high public use, and
- There is likely to be high level of public interest or concern on the issue and/or there are a significant number of affected parties.

The Council will prepare a local management plan, with full public consultation, to provide strategic management direction, for the long term. The management plan will address the range of management activities, including trees and vegetation.

### Explanation

The objective of the Council consultation processes is to reach an agreement that is acceptable to all parties and that adequately considers community well-being. The District Tree Strategy provides a consistent approach to dealing with such issues and allows for the provision of a high value tree resource. Consultation with individuals and/or groups in the community will be undertaken wherever it is required, in order to provide information, advice and an opportunity to comment or participate. For key areas of conflict, local management plans will be prepared with public consultation to ensure that all viewpoints are considered in deciding on long term management.

In general, the Council will consider all submissions on planned works on their merit on a case-by-case basis. Where immediate neighbours are the most affected by a proposed works their opinions will be weighted accordingly.

The observance of cultural protocols relating to trees on waahi tapu sites enable local tangata whenua to determine appropriate actions and responses by Council officers.

## Flow Chart for Assessing Applications – Community Facilities

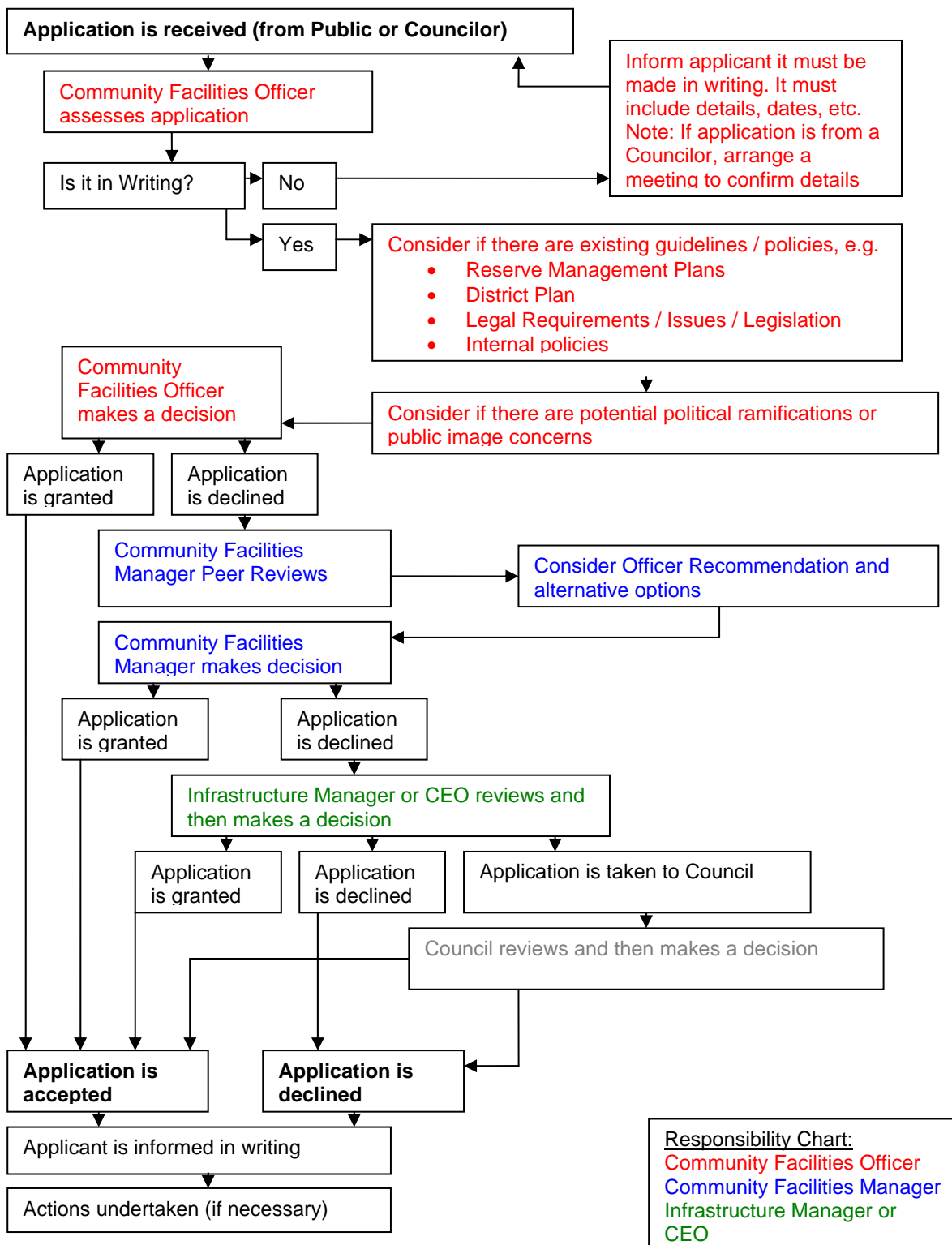

Figure 2 (Policy2.3.7.2)

## 2.8 Education and Promotion

One of the most effective methods of ensuring public stewardship of Council tree resources, and compliance with the Council policies related to trees, is to increase awareness through education and promotion. These education and promotion policies are intended to ensure that members of the public, developers, Council staff and elected officials have an understanding of the purpose and rationale behind the District Tree Strategy. They are also intended to support and augment the policies and methods of implementation in the District Plan.

### Objective 2.8.1

**To foster public interest, awareness and stewardship of the value of trees and other vegetation on Council administered land.**

#### Policy 2.8.1.1

Encourage the community to become involved in tree stewardship, through consultation and participation in Council organised programmes and events, such as Arbor Day plantings.

#### Policy 2.8.1.2

Promote the beauty and diversity of Council's treescapes during regional and national events.

#### Policy 2.8.1.3

Prepare and distribute promotional materials to increase awareness about the District Tree Strategy and its purpose and content. This includes publications, posters, displays and presentations. With information on:

- The types of vegetation present at a particular location.
- The values and benefits of trees and other vegetation, such as habitat values and contribution to biodiversity, shade, framing and softening landscapes, etc.
- Trees on public lands that can be used for food gathering e.g., fruit and nuts.
- Tree collections in the district.
- The importance of "the right tree planted in the right place".
- 'Street Site Character Areas for the district'
- The concept of 'trees as part of the view'.

#### Policy 2.8.1.4

Ensure that the most up to date version of the District Tree Strategy is available on the MPDC website and hard copies available for interested parties.

#### Policy 2.8.1.5

Council will work with developers, property agents and surveyors to increase awareness of the values and benefits of trees in developments and what is needed to maintain healthy and productive tree growth.

#### Policy 2.8.1.6

Council will also make information available on the tree policy and its implications for homeowners.

#### Policy 2.8.1.7

Information and activities will be made available to elected officials and Council staff to inform them about the District Tree Strategy and tree issues in the district.

#### Policy 2.8.1.8

Where appropriate to the circumstance, Council will consider partnering with tree advocacy groups, as well as other relevant groups such as environmental and wildlife organisations and educational institutions.

#### Explanation

The value of the Council's tree resource is often taken for granted by those who are routinely amidst it. However, it is a very significant landscape feature which gives an immediate impression to visitors to the district. A healthy and well maintained treescape is a reflection of a caring community. It is also a natural asset which is easily lost through poor management and lack of appropriate policy.

Many of the issues related to people's dissatisfaction with trees are attributable to a lack of awareness regarding the overall value of trees and their benefits. Policies that educate and inform the public about the positive attributes of trees are an important component of Council policies.

## 2.9 Tree Evaluation and Assessment

In developing policies on tree evaluation and assessment, Council seeks to ensure that it has a reliable and recognised system in place, based on international standards and methods, which can be used to assess the value of a tree and any risk that it poses to public health and safety.

### Objective 2.9.1

Consistent standards will be used to evaluate the health, condition and monetary value of trees, or any potential tree related hazards on Council administered land.

### Policy 2.9.1.1

The Royal NZ Institute of Horticulture (RNZIH) Tree Evaluation System (STEM) will be used as the standard for assessing the health, condition and monetary value of trees on Council land, unless superseded by a more appropriate method.<sup>10</sup> where a comparative assessment is necessary, the International Society of Arboriculture (ISA) valuation method will also be used and the average considered.

<sup>10</sup> Note: Notable Trees, Amenity Trees and Significant Natural Areas are assessed against Council specific criteria that are different to the RNZIH Tree Evaluation System.

### Policy 2.9.1.2

The ISA Tree Hazard Assessment Method or equivalent will be used as the standard for assessing the health and condition of any tree that has been reported or observed as potentially hazardous or unsafe.

### Explanation

There are situations where it is necessary to attribute a monetary value to a tree. These situations usually arise when the removal of a tree is proposed. It is important that in these situations the monetary value of the tree is assessed using a consistent evaluation system. The RNZIH Tree Evaluation System and ISA valuation method are currently the most appropriate nationally recognised assessment system.

Where trees are considered unsafe and represent a hazard to people or property a consistent evaluation system will be used. The ISA Tree Hazard Assessment Method is currently the most appropriate internationally recognised hazard tree assessment system.



## Part 2

### Arboriculture - Operations Manual



## Introduction

This manual defines the approach and practices to be undertaken by tree work contractors involved in arboricultural operations within the territorial area of Matamata-Piako District Council.

Contractors should adopt the arboricultural approaches and practices defined in this document whenever employed by MPDC.

The Community Facilities Division of MPDC are responsible for individual trees, groups of trees and areas of existing and regenerating bush on Council administered reserves, civic open spaces and other Council owned land. In addition the District Plan sets out the regulatory provisions for protected trees. The District Plan is administered by the **Planning team of the Council's Planning and Environmental Services Department.**

## 1.0 Arboricultural Operations

### Covering:

#### *1.1 Statutory Requirements*

- Codes of Practice
- District Plan provisions
- District Tree Policy

#### **Objective:**

To specify the standards for arboricultural operations in accordance with accepted modern arboricultural principles, whilst complying with all statutory requirements.

#### **1.1 Statutory Requirements**

Purpose: To identify and comply with all statutory requirements that are relative to tree maintenance operations.

## **Codes of Practice**

Tree maintenance operations shall be carried out in accordance with the Approved Code of Practice for Health and Safety in Tree Work, Part 1: Arboriculture, and all relevant regulations pertaining to the Health and Safety in Employment Act 1992.

Tree maintenance operations around electrical conductors must be carried out in accordance with the Approved Code of Practice for Safety and Health in Tree Work, **Part 2: Maintenance of Trees Around Power Lines**, the guidelines specifically given in Appendix A and all relevant regulations pertaining to the Health and Safety in Employment Act 1992. Personnel engaged in power line clearance work must be competent to perform such tree maintenance.

## **District Plan Provisions**

Tree maintenance operations must comply with the various Matamata-Piako District Council District Plan tree protection provisions.

## **District Tree Plan**

All tree maintenance operations must comply with the policies defined in the Matamata-Piako District Plan.

## **2.0 Tree Establishment**

**Covering:**

### **2.1 Site Selection**

Considerations

### **2.2 Transportation of Trees**

Transportation

Watering

### **2.3 Planting**

Planting season

Site preparation

Planting hole

Tree preparation

Tree placement and orientation

Backfilling planting hole

### **2.4 Support Systems**

Stakes and ties

Staking method

### **2.5 Mulching**

Mulch types

Mulching methods

### **2.6 Tree Isolation Systems**

Types of isolation systems

### **2.7 Protection Systems**

Types of protection systems

### **2.8 Transplanting**

Transplanting practice

**Objective:**

To successfully establish trees through appropriate site preparation, correct planting techniques and adequate physical protection systems.

**2.1 Site Selection**

Purpose: To provide appropriate planting sites that allow trees to fully develop and mature without conflict with surrounding features.

**Considerations**

- Tree plantings will take into account all policies within the District Tree Strategy; particularly those defined in 2.1 Tree Planting and 2.7 Consultation.

**To install appropriate root barriers as required**

To be a minimum distance of 700mm from the kerb

The location of the tree to be 3.0 metres from sewer laterals

**2.2 Transportation of Trees**

Purpose: To provide appropriate care in the handling and transportation and handling of tree nursery stock to ensure a minimum of damage.



## **Considerations**

- Plant material will be handled and transported to avoid any damage to plants.
- Bare root plants will be watered and protected by soil, mulch, scrim or similar materials to prevent root damage and drying. Special care will be required to retain as much soil on bare root plants as possible.
- Containerised plants with roots that do not fully fill the container will be lifted by the container; not the stem.
- Plant materials will only be stored at the site with the approval of the Community Facilities Officer
- Any plant material held or transported on site will be protected from stock, environmental conditions or theft.

## **Watering**

Trees may require irrigation if there is a longer period than twenty-four hours between the collection of trees and planting. Container grown trees will be watered thoroughly on the day of planting, unless otherwise specified by the CF Officer.

## **Plant Collection and Return**

Unless specified to the contrary, all plant material will be collected by the contractor from Nominated Nursery during the normal hours of work. Plant collection outside of normal working hours will be arranged directly between the nursery and the contractor.

## **2.3 Planting**

Purpose: To provide appropriate site preparation and planting techniques that result in successful tree establishment.

### **Planting Season**

Tree planting will occur during autumn and winter (April– September), unless otherwise specified by the CF Officer.

### **Site Preparation and Design**

- The contractor must ensure that all underground services that are in the vicinity of works are defined and located prior to any excavation.
- Planting will not commence until all preparation works specified in the work instruction are approved by the CF Officer
- The CF Officer may interpret the design on site and advise/assist the contractor to implement the design.
- The contractor will advise the CF Officer in advance of the day of planting two working days before the event.

## Planting Holes

Planting holes must be both wide enough and deep enough to accommodate the entire root system, with room for roots to spread. The planting hole diameter should be 20-30cm wider than the root system, unless otherwise specified by the CF Officer.

Planting holes may be tapered. Where tapered planting holes are specified, the top of the hole should be 2-3 times as wide as the root ball and the bottom of the hole should be 20-30cm wider than the root ball. (Refer Figure 2.1).

When preparing tapered planting holes, it may not be necessary to remove all of the soil then put it back in the hole. It may be more efficient to first dig the planting hole 20-30cm wider than the root ball, and then widen the hole by partially backfilling with soil as the hole is widened. (Refer Figure 2.2).

The sides of the planting hole must not be left smooth or glazed as this may inhibit root development. Pan soil at the base of the planting hole should be broken up to improve drainage. Backfill soil should be added to the bottom and consolidated but not compacted so the root ball will not settle.

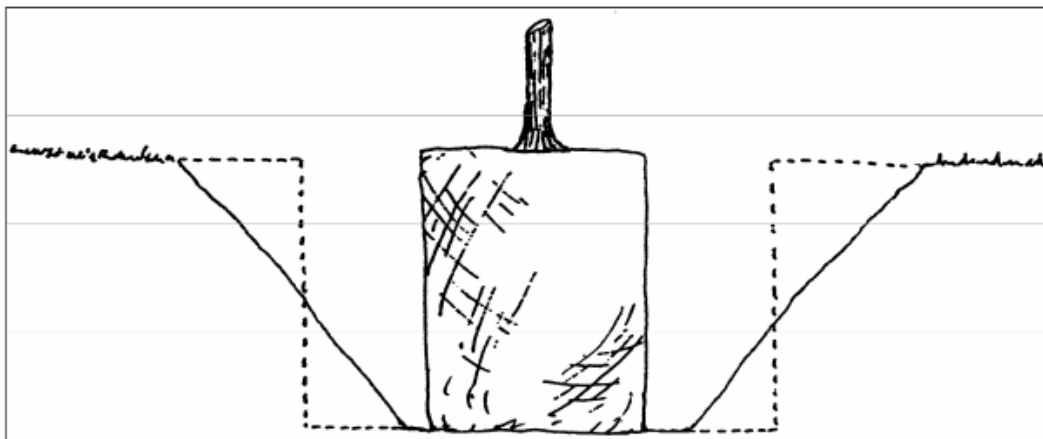

**Figure 2.1**

*The planting hole should be only as deep as the root ball. Compared to a hole with vertical sides of the same volume a hole with sloped sides may be easier to dig and provides an increased volume of friable soil for vigorous root development.*

Planting holes for container grown trees must be no deeper than the root ball. If the planting hole is initially dug too deep soil must be added to the bottom and firmed so the root ball will not settle.

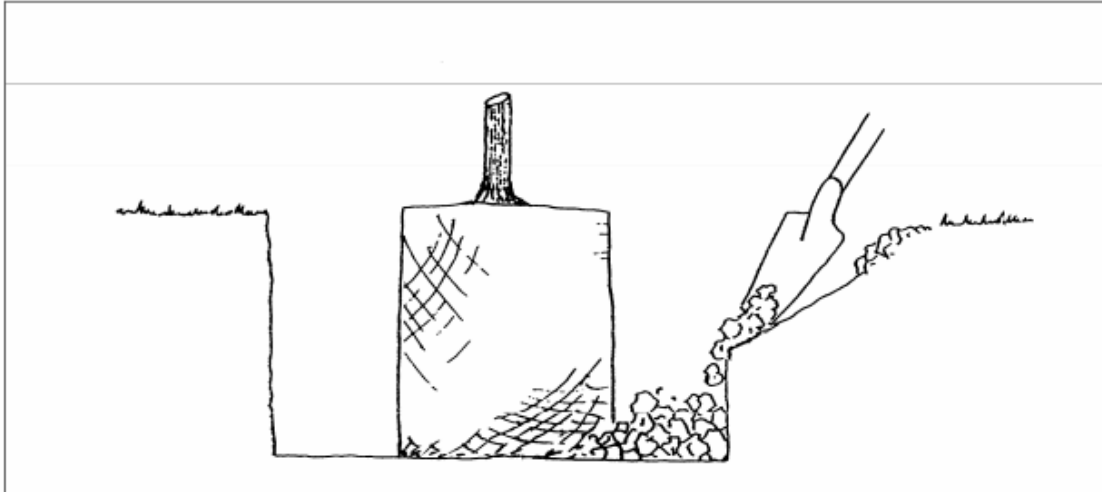

**Figure 2.2**

*The planting hole may be excavated 20-30cm wider than the root ball and then partially backfilled as the hole is widened.*

All debris, weeds and grass must be removed from the planting site. Turf removed to create the planting hole must not be backfilled into the planting hole.

Planting holes must be excavated a minimum of 150mm wider and 150mm deeper than the root ball. For large trees the planting hole minimum dimensions should be:

- 1.5 - 2.5m trees: 300 x 300 x 300
- 2.5 - 3.5m trees: 750 x 750 x 500
- 3.5 - 5.0m trees: 1m x 1 m x 500

The base of the planting hole must be forked to a minimum depth of 100mm and any stones over 50mm diameter or poor quality soil must be removed from the hole. The sides of the planting hole should also be loosened, and the surrounding ground to two times the root ball diameter to be 'forked' over to reduce compaction.

### **Tree Preparation**

Trees growing in containers must be watered thoroughly on the day of planting, unless otherwise specified by the appointed CF officer.

Damaged branches must be removed at the time of planting. The tree should be pruned to accommodate the site requirements, including formative pruning.

Container materials, tags, and restrictive ties bindings and must be removed prior to planting.

Bare rooted trees should be placed in a hole that is both wide enough and deep enough to accommodate the entire root system. Roots should be straightened to prevent kinking, crowding and crossing of main roots.

Any damaged, diseased, circling or girdling roots and any unusually long roots that will not fit into the hole without bending should be removed with sharp pruning shears prior to planting.

Container grown trees must be checked to ensure that the first roots emerge from the stem at the soil surface or just below the surface, as settlement may have occurred within the container or during nursery production.

Container grown trees must be checked to ensure that roots are not circling within the root ball. Where superficial circling roots on the surface of the root ball are encountered, several vertical cuts down the outer edge of the root ball should be carefully made with a sharp spade or pruning shears to sever the circling roots prior to planting.

Some container grown trees may require the 'butterfly technique' to sever circling roots deep within the root ball (Refer Figure 2.3). The 'butterfly technique' involves:

- 1) Remove the tree from the container.
- 2) Cut any circling roots on the surface of the root ball with sharp pruning shears.
- 3) Run a sharp spade through the diameter of the bottom third to one half of the root ball using a single cut.
- 4) Spread the root ball apart to splay out the lower third to one half of the root system.
- 5) Place the tree on a slightly raised mound at the bottom of the hole to match the indent of the splayed root system.

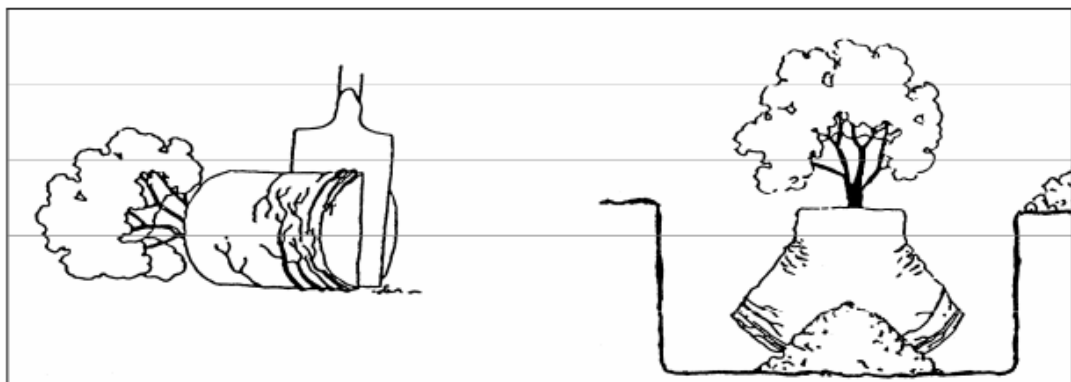

**Figure 2.3**

*The 'butterfly technique' should be used to disrupt circling roots that are sometimes found in container grown trees.*

## Tree Placement and Orientation

- The trees must be set vertically and planted so the top of the root system is at grade ie level with normal (in 1.5cm above/below), unless otherwise specified by the appointed CF officer.
- Trees planted in tree surrounds may be planted slightly proud of the surrounding soil surface level to compensate for contained mulch depth, as specified by the appointed CF officer.
- Consideration should be given to the most appropriate orientation of the tree in relation to possible effects on surrounding features as the tree develops i.e. branches overhanging/obstructing the carriageway.

## Backfilling Planting Hole

Backfill material must be free of unbroken earth clumps, rock, weeds, grass and foreign objects. In most cases the planting hole should be backfilled with the original soil excavated from the hole. Excavated soils that are of poor quality (such as soils of high clay or rock content) should be amended with a quality soil medium as approved by the appointed CF officer.

Soil conditioners, fertilisers, chemicals or water aids may be added to backfill or plant in accordance with the manufacturers recommendations and on instruction of the appointed CF officer.

The tree should be held in position while backfill is placed around the root ball.

The backfill should be firmed gently to expel air pockets. Excessive tamping should be avoided since this may over-compact soil, reducing water penetration and root growth.

The tree must be checked to ensure that the planting level is correct, and the tree is vertical. All surplus material and refuse must be removed from the site.

Trees may require watering-in at the time of planting. This may depend on weather conditions and site and species requirements. Water must be applied at low pressure to the base of the tree, from a distance of less than one metre. Care must be taken to avoid moving soil or mulch away from the tree base with water.

All plants must be supplied true to the species and grades specified on the approved landscape plans. All street trees, unless specified otherwise, must be of a minimum grade of: 2.0m with a 30mm calliper.

Other tree grades shall be supplied as follows:

1.5m - 2.5m specimens shall have a calliper of 30 - 50mm

2.5m - 3.5m specimens shall have a calliper of 50 - 70mm

3.5m - 5m specimens shall have a calliper of 70 - 100mm

All other stock shall be of minimum pb3 grade for groundcover and pb5 grade for shrubs.

All plants to be advanced specimens for their grade and to be well furnished and rooted relative to container size.

No substitution of species or grade may be made without the written approval of the appointed CF officer. If species or grades specified are unobtainable, the appointed CF officer may approve alternatives. Smaller grades may require an increased planting density and numbers, which will be at the Contractor's expense.

All plant material supplied must be clearly labelled stating the plant's Latin name and the supplier's name, (one label per plant group planted). These labels must be removed on completion of planting.

The Contractor must give the appointed CF officer no less than five days notice of dates on which plants are to be delivered on site, so that arrangements can be made for quality inspection and confirmation of identification of plant material.

Plants must be well branched, symmetrical and of typical habit for the species. All plants must be nursery stock of good form, healthy and vigorous with strong fibrous root systems and free of all pests and diseases.

All trees must be supplied with the central leader intact - no pruning of the central leader may have taken place. All torn or damaged roots must be pruned before dispatch. All stock must be well rooted but not rootbound. Open ground stock should be well-wrenched.

All root balls and containers must be free of all weeds. Plants shall be well 'hardened - off' prior to supply.

The Contractor should ensure that all plants and their roots can be maintained in a moist environment, protected from adverse conditions such as drying winds, frost or water logging. All roots must be covered during transit and storage to prevent desiccation or damage.

## 2.4 Support Systems

Purpose: To provide temporary support which aids the establishment of newly planted trees.

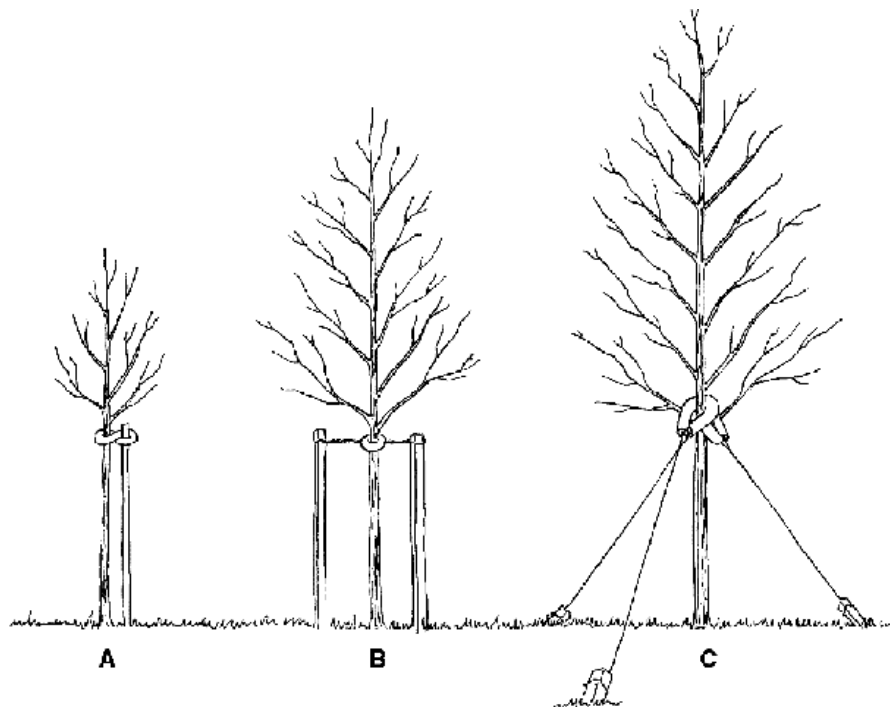

Figure 2.4

### Stakes and Ties

Staking methods will be specified in the planting instruction by the appointed CF officer.

### Staking Method

Stakes must be driven firmly into the ground, at a distance from the tree that is just beyond the root ball. Ties should be secured to each stake at approximately one third the height of the tree or within 100mm of the top of the stake. Each tie should be taut, but should not pull the tree towards the stake. The intention is to keep the tree in place while permitting the top to move freely, as such crown movement may encourage increases in stem diameter and root development.

Stakes should be neatly and vertically placed in a consistent pattern and tied at a similar height using the same method. Street trees with two stakes should have the stakes positioned parallel with the road kerb, unless otherwise specified by the appointed CF officer.

## 2.5 Mulching

Purpose: To provide an environment at the base of newly planted trees that will encourage successful establishment.

### Mulch Types

Wood chip mulch from tree trimming operations shall be well composted, free of weeds and weed seeds and will have no inorganic content.

Granulated pine bark may be the preferred mulch used in tree surrounds in high profile areas, as specified by the Manager of community facilities or nominated officer.

### Mulching Methods

Newly planted trees must be mulched, when specified by the appointed CF officer.

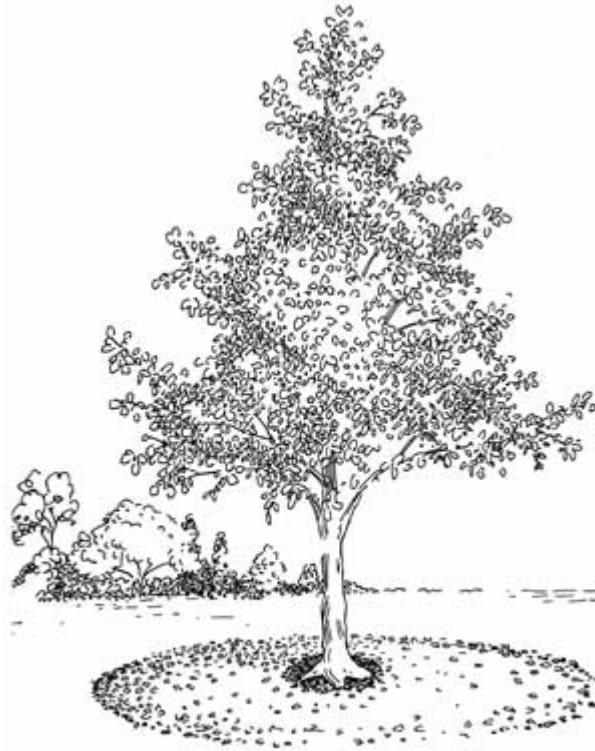

Mulch wide—not deep.

Figure 2.5

Where tree surrounds are used mulch must be contained within the surrounds to a depth of 75-100mm.

Where tree surrounds are not used the mulched area must be maintained at 600mm diameter and 75-100mm depth of a 1m diameter

Mulch should be kept clear from the trunks of young trees.

## **Tree Isolation Systems**

Purpose: To assist tree establishment by providing an environment at the base of trees that is isolated from surrounding turf or hard surface treatment and by containing mulch.

### **Types of Isolation Systems**

The type of tree isolation system to be used will be specified by the appointed CF officer.

Moulded plastic tree surrounds, where used, must be installed as recommended by the manufacturer.

Tree surrounds, where used, must be installed neatly, in a consistent pattern, at an even spacing parallel to kerbs and shall be set flush with surrounding ground levels. Surrounds should be installed with adequate room for domestic lawn mowers to pass between the surrounds and adjacent features.

The final alignment, spacing and positioning of tree surrounds will be specified by the appointed CF officer.

### **Mulch is beneficial because it:**

- Prevents erosion,
- Conserves soil moisture and keeps tree roots cool during summer,
- Buffers low temperature extremes during winter freezes,
- Suppresses germination of weed seeds,
- Is aesthetically pleasing,
- Helps provide unity among a group of planting beds.

## **Mulching Recommendations:**

- Identify plant and its moisture / low oxygen tolerance.
- Determine current mulch depth; tine rake to aerate / dry.
- Use composted mulches only.
- Well-drained soils: apply 50 mm (fine mulch) to 100mm (coarse).
- Poorly drained soils: apply 50mm maximum.
- Very poorly drained soils: use chemical weed controls.
- Keep mulch 100mm (young trees) to 200mm (old trees) from trunk.
- Soil test periodically for pH.
- Avoid “sour” smell (ammonia) mulches.
- Excavate soil to expose trunk flare; use coarse aggregate to fill.
- Irrigation should not flood trunk or trunk flare.
- Tine rake any slime mold or fungal mats to aerate.
- Mulch out to the drip line if possible.
- Share this knowledge with others. Avoid “mulch volcanoes”.

## **2.7 Protection Systems**

Purpose: To provide physical protection against damage caused by vehicles, pedestrians and machinery in high usage areas, or stock in grazed areas.

### **Types of Protection Systems**

Various protection systems may be specified by the Asset Officer. These systems may include trunk guards, bollards, gro-tubes and cages and any specific requirements of the District Plan or resource consent.

## **2.8 Transplanting**

Purpose: To undertake appropriate practices which ensure tree transplanting success.

### **Transplanting Practice**

Tree transplanting operations should be carried out as specified by the appointed CF officer.

Tree transplanting operations must be undertaken in accordance with accepted modern arboricultural practices and must comply with resource consent regulations and bylaws.

### **3.0 After-Care Maintenance**

#### **Covering:**

#### **3.1 Maintenance Periods**

Considerations

After-care maintenance cycle

#### **3.2 Maintenance Tasks**

Support systems

Mulch

Weed control

Isolation and protection systems

Pruning juvenile trees

Fertiliser application

Removal and replacement

Watering

#### **Objective:**

To maintain optimum growing conditions for newly planted trees to ensure successful establishment. This will be achieved by undertaking various after-care maintenance tasks throughout the year. All materials and practices used will be consistent with those specified in section 2.0 Tree Establishment.

#### **3.1 Maintenance Periods**

Purpose: To provide timely and planned inspections and after-care maintenance to assist in the healthy establishment of juvenile trees.

#### **Considerations**

After-care maintenance operations will take into account all policies within the District Tree Strategy, particularly those defined in 4.1 Tree Planting, 4.2 Maintenance of Trees, 4.3 Tree Removal and 4.4 Consultation.

#### **After-care Maintenance Cycle**

The after-care maintenance period for newly planted trees will be specified by the appointed CF officer.

### **3.2 Maintenance Tasks**

Purpose: To provide appropriate after care-maintenance practices that ensures optimum tree establishment and healthy growth.

#### **Support Systems**

Stakes and ties will be maintained to provide support to juvenile trees as specified in section 2.4 Support systems.

The contractor will periodically check all trees that are staked and adjust or replace ties as necessary to prevent damage to the tree, or risk to public safety. As a general rule stakes should be removed after one growing season in situ.

#### **Mulch**

Mulch around the base of trees will be maintained in a tidy and functional condition, as specified in section 2.5.

#### **Weed Control**

Weed control will be carried out during planned after-care maintenance visits to ensure the bases of trees retain a tidy appearance, free of invasive grasses and weeds, with a defined edge.

#### **Isolation and Protection Systems**

Maintenance of tree isolation and protection systems will be undertaken as part of the planned after-care maintenance programme.

Tree surrounds in grass and sealed areas will be maintained, secure and correctly positioned.

Tree isolation and protection systems will be maintained to provide a tidy appearance and to prevent risk to public safety.

#### **Pruning Juvenile Trees**

Pruning will be carried out as specified in section 4: Pruning.

Remedial and formative pruning will be carried out as required.

Formative pruning consists of the selective removal of specific branches to enhance form and improve structure, or to directionally shape the tree in accordance with site constraints. Co-dominant stems, crossing and rubbing branches and branches with potentially weak unions that could fail in adverse weather conditions should be removed. Basal shoots and undesirable growth should also be removed. For most street trees, a clear trunk should be maintained from ground level to approximately one third of the tree's height, unless otherwise specified by the appointed CF officer.

## **Fertiliser Applications**

All trees will require applications of slow release fertiliser at the time of planting and may require additional applications of a general purpose fertiliser during the maintenance period, applied to optimise growth potential.

## **Soil Laboratory Testing**

At the Council's discretion, when trees are to be planted, the topsoil may require nutrient laboratory testing.

- a If the topsoil has already been installed on site or existing in situ topsoil is being used for planting, a minimum of 10 soil samples will be taken throughout the site.
- b If the topsoil has yet to be installed then a minimum of 3 soil samples will be taken at its source, ensuring that the same topsoil tested is installed on the site after Council has approved its use.

Soil samples will be taken as per sampling instructions provided by the soil testing laboratory. The laboratory results and a plan indicating sample site locations will be provided to Council prior to planting. Planting must not proceed without Council soil test approval. Council reserves the right to undertake further topsoil sample testing prior to soil test approval should it be deemed necessary.

Where sample results are beyond acceptable parameters, the topsoil must be modified To ensure that it aligns within these parameters or another conforming topsoil source must be identified to be used for planting. Soils with a high pH level may require Extractable Aluminium testing at Council's discretion.

## **Removal and Replacement**

Juvenile trees will be removed as part of the planned after-care maintenance programme and as required when they are:

- Dead
- In irreversible decline
- Damaged or vandalised beyond repair

The Assets Officer will be informed of juvenile tree removals and a record will be kept for replacement planting and asset management purposes.

Where the trees formed part of any landscaping required as a District Plan permitted standard or a resource consent condition it will be replaced.

Materials such as stakes, tree isolation and protection systems may be retained as specified by the Assets Officer.

## Watering

- Supplementary watering may be carried out in addition to other planned after-care maintenance visits, as specified by the appointed CF officer.
- Each tree should receive a minimum of twenty litres of water per application.
- Water will be applied at low pressure to the base of the tree, from a distance of less than one metre. Care must be taken to avoid the displacement of soil or mulch whilst undertaking watering.

## **4.0 Pruning**

**Covering:**

### **4.1 Modern Arboriculture**

Considerations

Approach to pruning

### **4.2 Pruning Practices**

Relevant Codes of Practice and associated regulations

Formative pruning

Crown lifting

Cleaning out (including removal of deadwood)

Crown thinning

Crown reduction

Remedial pruning

Pollarding

### **4.3 Power Line Clearance**

Relevant Codes of Practice and associated regulations

Required standards

Optimum power line clearance

#### **Objective:**

To undertake pruning operations in accordance with modern arboriculture practices, the policies defined in the District Tree Strategy and within the tree protection provisions of the District Plan, which will ensure the long term health and viability of trees in parks, reserves and streets.

## 4.1 Modern Arboriculture

Purpose: To specify tree management techniques which are in accordance with modern arboricultural practices, Natural Target Pruning (NTP) methods and Compartmentalization of Decay in Trees (CODIT) theories.

### Considerations

Arboricultural operations will take into account all policies within the District Tree Policy, particularly those defined in 4.1 Tree Planting, 4.2 Maintenance of Trees, 4.3 Tree Removal and 4.4 Consultation.

### The Approach to Pruning

Natural Target Pruning is the removal of a branch, stem or stub in such a way that a final cut is made as close as possible to the branch collar without cutting into the branch collar or leaving a protruding stub. The aim is to prevent damage to the remaining branch or trunk tissue. (Refer Figures 4.1, 4.2, 4.3 and 4.4).

Consideration must always be given to the species, health, age, condition and location of the tree, as well as the reason for pruning the tree. Care must be taken to avoid excessive pruning.

Pruning should allow for the natural distribution of foliage and weight along branches and branch ends according to tree species and stages of maturity.

Removal of large branches should only be carried out when it is unavoidable and wounds resulting from such work must be kept to a minimum.

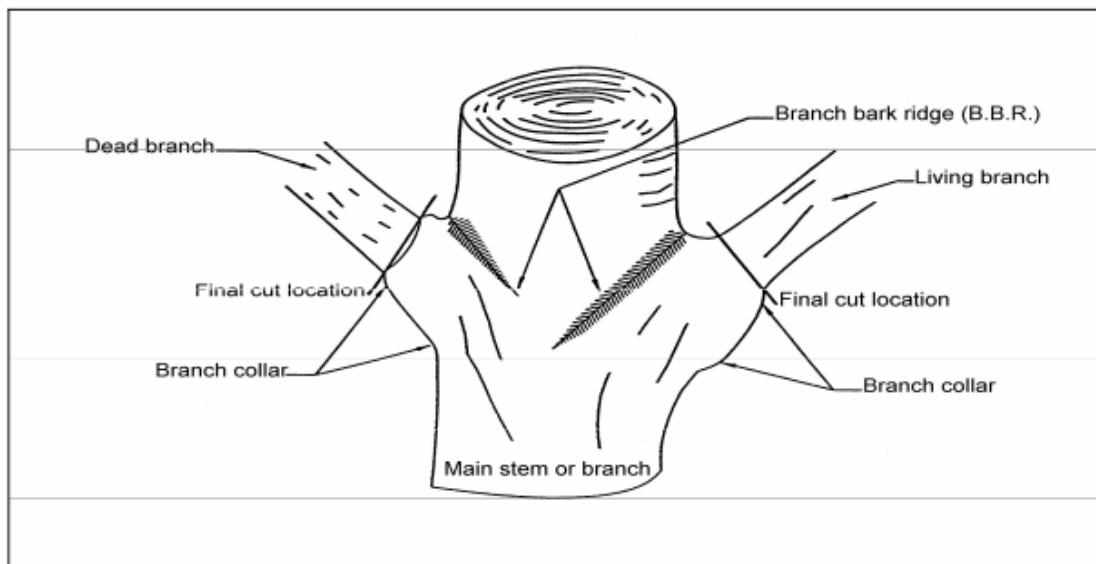

**Figure 4.1:**

*Remove branches, stems and stubs so final cuts are made as close as possible to branch collars without cutting into branch collars or leaving protruding stubs.*

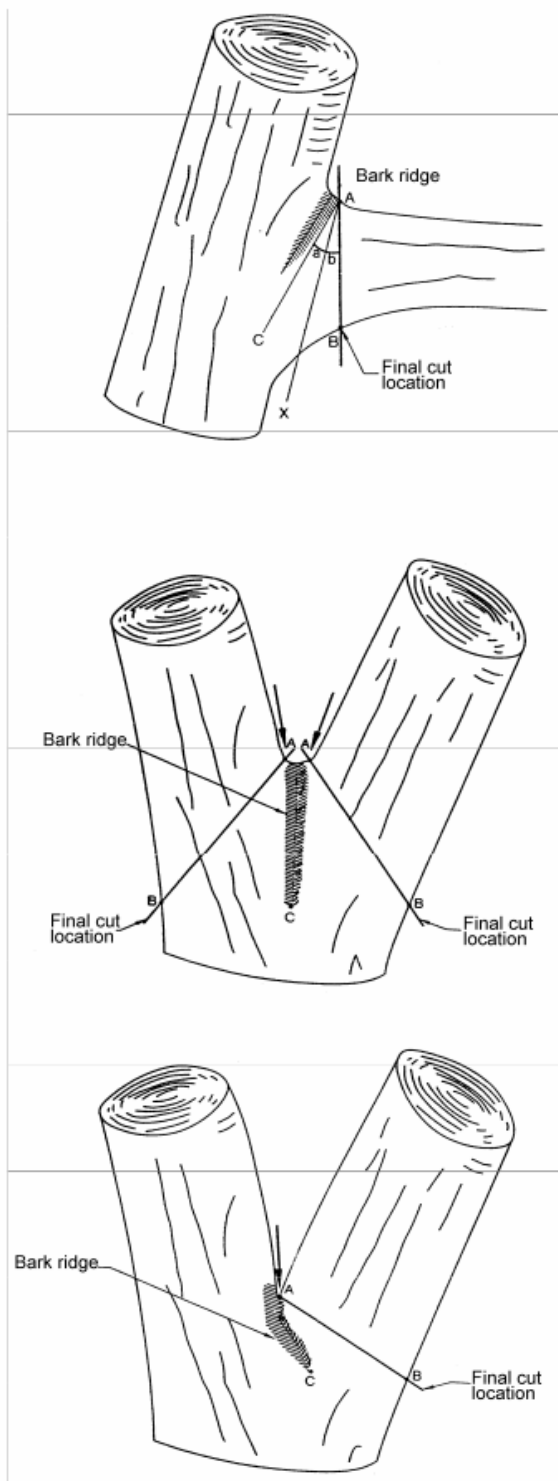

**Figure 4.2:** On living branches where the branch collar cannot be located the branch bark ridge can be used as a guide.

**Line A-X** is a line parallel to the stem or trunk occurring just outside the branch bark ridge. **Line A-B** represents the angle and location of the final cut.

**Figure 4.3:** On branches with extruded stem bark ridge.

**Line A-B** represents the angle and location of the final cut.

**Point C** indicates the bottom of the stem bark ridge.

**Point B** is directly across from **Point C**.

**Figure 4.4:** On branches with included bark.

**Line A-B** represents the angle and location of the final cut.

**Point C** indicates the bottom of the stem bark ridge.

**Point B** is directly across from **Point C**.

Note: These figures are a guide only.

**Figure 4.2**

## **4.2 Pruning Practices**

Purpose: To undertake tree pruning practices that result in trees being maintained to the standards defined in the District Tree Strategy the tree protection provisions of the District Plan and to meet public safety requirements.

### **Relevant Codes of Practice and Associated Regulations**

Tree maintenance operations must be carried out in accordance with the Approved Code of Practice for Safety and Health in Tree Work, Part 1: Arboriculture, the guidelines specifically given in Appendix A and all relevant regulations pertaining to the Health and Safety in Employment Act 2002

Tree maintenance operations around electrical conductors shall be carried out in accordance with the Approved Code of Practice for Safety and Health in Tree Work, Part 2: Maintenance of Trees Around Power Lines, the guidelines specifically given in Appendix A and all relevant regulations pertaining to the Health and Safety in Employment Act 2002. Personnel engaged in power line clearance work must be competent to perform such tree maintenance.

### **Formative Pruning**

Formative pruning should be performed on juvenile trees as they establish, or as required by the Asset Officer, (section 2.3 & 3.2).

### **Crown Lifting**

Crown lifting is the removal of the lowest branches. The actual clearance height achieved will vary with individual trees, depending upon their age, size, form and habit. The natural shape of the tree should be preserved as much as possible.

For young trees, to minimise stress on trunks and to develop or maintain good trunk taper, at least one-half of the foliage distribution should be retained on branches that arise in the lower two-thirds of the trunk.

Crown lifting of young trees should not exceed more than one third of the total height of the tree, unless otherwise specified by the appointed CF officer.

For semi-mature and mature trees crown lifting and lateral branch reductions shall be carried out to retain natural crown shapes. In many cases these clearances must be 2.5m to 3.0m (minimum range) above footpaths and 3.5m to 4.5m (minimum range) above carriageways. This should be achieved by the removal of only those parts of the branch which extend below the desired clear height. Entire branches may require removal as directed by the appointed CF officer.

**Cleaning Out** (including removal of deadwood)

Cleaning out consists of the removal of dead, diseased, dying, defective, suppressed and conflicting branches.

Cleaning out should include the removal of foreign objects and plant matter deemed to be detrimental to the tree, when this can be done without inflicting undue damage to the tree and as specified by the appointed CF officer.

The extent of dead wooding and the diameter size of dead wood to be removed will be determined on a site by site basis, as specified by the appointed CF officer.

Cuts into live wood should always be avoided when removing dead wood and stubs. In cases where the deadwood has remained in extend itself along the dead branch, this collar should be left intact. (Refer Figure 4.2.1).

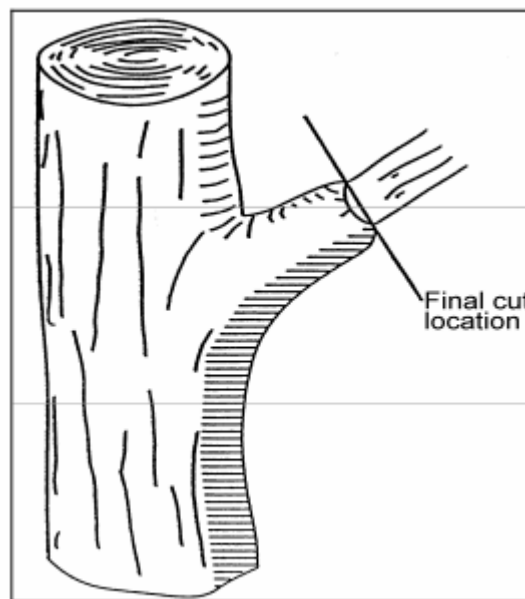

**Figure 4.2.1**

*The branch collar should be left intact.*

## Crown Thinning

Crown thinning is cleaning out with the additional removal of secondary healthy and sound branches to produce an even density of foliage and a well-spaced and balanced branch structure.

Crown thinning may be carried out to lessen wind resistance, to reduce the weight of limbs, to increase light penetration and air movement through the crown and (where agreed in relation to the District Plan provisions and adopted policies) to assist in restoring views.

The percentage area of thinning is variable, depending upon the age, size, form and growth habit of the tree. The branch volume and leaf area removed must not exceed 20% unless otherwise specified by the appointed CF officer.

Reduction pruning is carried out to reduce tree height or spread. The ends of branches or stems are removed to internal branches, stems or growth points. (Refer Figure 4.6).

The branch or stem to which the final cut is made should be at least one-third of the diameter of the branch or stem being reduced at the point of the final cut. This may be difficult to achieve when undertaking remedial pruning and power line clearance.

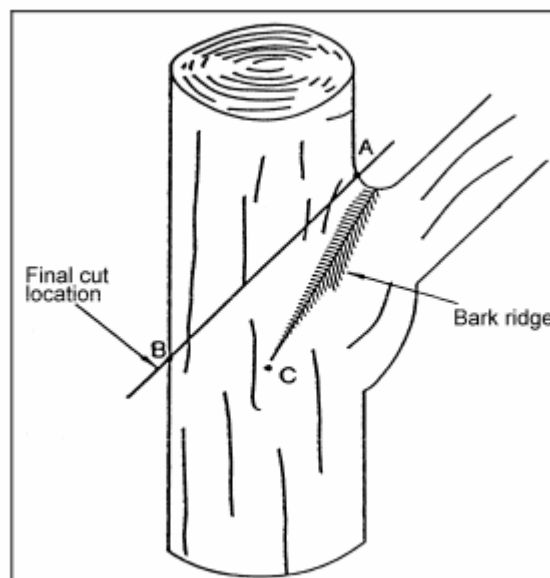

**Figure 4.2.2:**

*Where reduction pruning is undertaken Line A-B represents the angle of the final cut. Point C indicates the bottom of the bark ridge. Point B is directly across from Point C.*

## **Crown Reduction**

Reduction pruning is usually carried out in conjunction with power line clearance pruning and is not a recommended practice for normal tree maintenance, unless otherwise specified by the appointed CF officer.

Maintenance of some tree species located beneath overhead power lines may require crown reduction pruning to be carried out using hedge trimmers. Care must be taken to avoid producing a 'topped' or 'lopped tree' appearance. The natural shape of the tree must be preserved as much as possible, unless otherwise specified by the appointed CF officer.

## **Remedial Pruning**

Remedial pruning involves the removal of hazardous, damaged, diseased or poorly pruned branches back to undamaged or healthy tissue to ensure public safety and to improve the overall appearance of the tree.

Hazardous branches must be removed immediately to ensure public safety.

Trees must be monitored where this type of pruning is planned to be carried out in several stages, in an attempt to induce stable and successful regrowth.

## **Pollarding**

Pollarding is the regular pruning back of branch growth to a set position, in order to maintain the crown within specified dimensions. Pollarding usually occurs in autumn and includes the removal of seasonal growth back to the pollarded head, as specified by the appointed CF officer.

Cuts should be made as close as possible to the swollen collars that surround each shoot. Care must be taken to avoid damaging the pollard heads.

Basal growth of pollarded trees must also be removed during the pollarding operation and may require successive removal during the summer growth period, as specified by the appointed CF officer.

### **4.3 Power Line Clearance**

Purpose: To maintain trees in close proximity to power lines, in accordance with statutory requirements and industry Codes of Practice. The outcome will be to retain natural tree form as much as possible.

#### **Relevant Codes of Practice and Associated Regulations**

Tree maintenance operations around electrical conductors must be carried out in accordance with the Approved Code of Practice for Safety and Health in Tree Work, Part 2: Maintenance of Trees Around Power Lines. Personnel engaged in power line clearance work must be competent to perform such tree maintenance.

#### **Required Standards**

Trees located beneath overhead services (such as power lines and telephone wires) must be pruned such that the minimum clearance between the tree and the overhead service is maintained at all times. The minimum clearance distances for trees beneath overhead services given in the table below will apply:

**CODE OF PRACTICE FOR POWERLINE  
CLEARANCE AROUND VEGETATION**



**Table 2** Urban and Rural Areas – Low Voltage Aerial Bundled Cable and Insulated Service Cable.

Type of Powerline	Clearance Zone			Low Growth Zone
	Vertical above conductor	Horizontal outside conductor	Vertical below conductor	Max vertical above ground
Aerial bundled cable	0.5 m	0.5 m (urban) 1.0 m (rural)	1.0 m	4.0 m
Insulated service cable	0.5 m	0.5 m	0.5 m	

**Figure 2 – Clearance Profile – Low Voltage ABC and Insulated Service Cable**

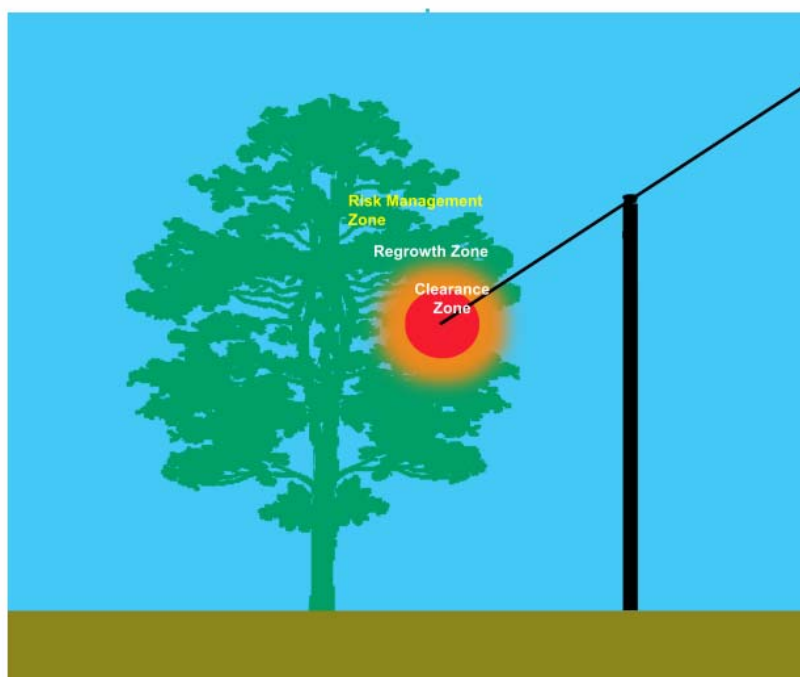

- The clearance zone for aerial bundled cable and service cables near the pole, as specified in column 2, may be reduced where tree trunks and limbs present no risk of abrasion. Foliage that will not abrade the ABC will be permitted in the clearance zone.

**CODE OF PRACTICE FOR POWERLINE  
CLEARANCE AROUND VEGETATION**



**Table 1     Urban Areas - Bare Wire Conductor Systems**

Type of Powerline	Clearance Zone			Low Growth Zone
	Vertical above conductor	Horizontal outside conductor	Vertical below conductor	Max vertical above ground
Bare low voltage	2.0 m	1.0 m (urban) 2.0 m (rural)	1.0 m	4.0 m
Bare 11 kV, 33 kV	3.0 m	2.0 m (urban) 3.0 m (rural)	2.0 m	

**Figure 1 – Clearance Profile for Bare Wire Conductor Systems**

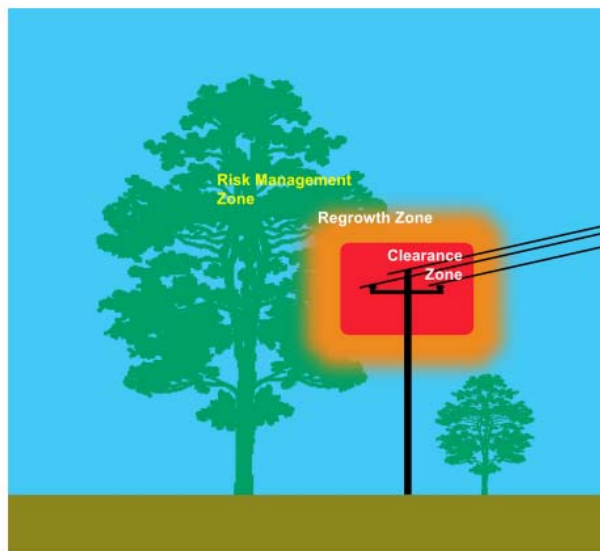

- Clearance Zone is the space surrounding a powerline that must be clear of vegetation at all times, including the period between trimming cycles.
- Regrowth Zone is a space beyond the clearance zone that must be maintained (trimmed) so that the regrowth does not enter the clearance zone within the trimming cycle
- Risk Management Zone is a space outside the clearance and regrowth space in which unsound trees or limbs may pose a risk in adverse weather conditions due to factors such as instability and weakness due to disease, fractures and rot.
- Low Growth Zone is the space below the clearance zone where vegetation is allowed which will not have a height of more than a specified distance, depending on the circumstance.
- The presence of limbs and foliage growing over the powerline is strongly discouraged. In some instances healthy and stable limbs may remain, provided the tree is not easily climbable and the powerline voltage is less than 33,000 volts. For sub-transmission powerlines, this is not normally permitted.

## CODE OF PRACTICE FOR POWERLINE CLEARANCE AROUND VEGETATION



Figure 3. Rural and Sub Transmission - Bare Wire Conductor Systems  
Corridor Profile

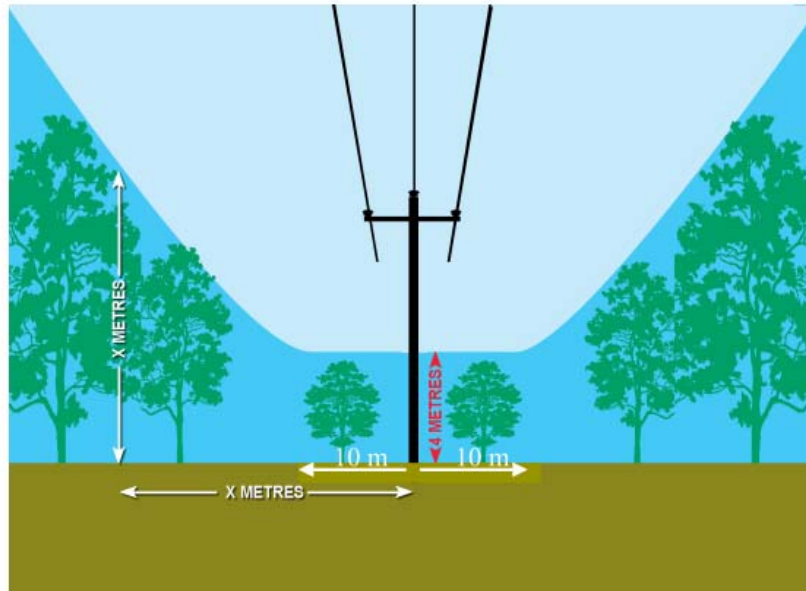

- Vegetation that cannot fall into the powerline can remain.
- Vegetation with a mature height less than four metres may remain under the powerline, however a working area around the pole or structure must remain clear to allow access for maintenance and repair.
- A corridor of low growing vegetation may be retained to allow connectivity of wildlife habitat.
- Safe access must be provided for maintenance vehicles.
- In fire prone areas, density of vegetation will be managed to prevent accumulation of fuel.

### **Optimum Power Line Clearance**

The distances listed above are the minimum clearances required. Greater power line clearance distances may be desirable where possible, to allow for seasonal regrowth, as specified by the appointed CF officer.

Power line pruning should be carried out in a manner sympathetic to the tree and in accordance with the principles outlined in section 4.1 Modern Arboriculture.



**Power line clearing around trees**

## 5.0 Tree Removals

Covering:

### 5.1 Health and Safety

- Considerations
- Relevant Codes of Practice and associated regulations
- Hazardous trees
- Surrounding features

### 5.2 Consultation

- Considerations
- Approval
- Notification

### 5.3 District Plan

- Protected tree provisions

### 5.4 Stump Treatment

- Safety
- Timing
- Stump grinding standards
- Alternative methods

### Objective:

To successfully undertake tree removal operations as required, whilst complying with all relevant health and safety, District Tree Strategy, District Plan, resource consent and consultation requirements.

### 5.1 Health and Safety

Purpose: To undertake safe and proficient tree removal operations.

### Considerations

Tree removal operations will take into account all policies within the District Tree Strategy, particularly those defined in 2.1.3 Tree Removal and 2.7 Consultation.

## **Relevant Codes of Practice and Associated Regulations**

Tree removal operations must be carried out in accordance with the Approved Code of Practice for Safety and Health in Tree Work, Part 1: Arboriculture, the guides specifically given in Appendix A and all relevant regulations pertaining to the Health and Safety in Employment Act 2002.

Tree removal operations around electrical conductors must be carried out in accordance with the Approved Code of Practice for Safety and Health in Tree Work, Part 2: Maintenance of Trees Around Power Lines, the guides specifically given in Appendix A and all relevant regulations pertaining to the Health and Safety in Employment Act 2002. Personnel engaged in power line clearance work must be competent to perform such tree maintenance.

## **Hazardous Trees**

- Hazard trees will be given priority.
- Hazard trees may include any specimen under MPDC jurisdiction.
- Whole trees will be removed immediately when they are creating an immediate significant hazard caused by a structural tree defect that cannot be minimised or isolated. Photographs will be taken of the tree, together with a condition report, prior to removal. The appointed CF officer must be notified of such tree removals immediately during normal working hours or by 9.00am of the next working day.

## **Surrounding Features**

Care must be taken to avoid damage to property, features, neighbouring trees and sub-canopy planting.

## **5.2 Consultation**

Purpose: To provide accurate and timely information to Matamata-Piako District Council staff and customers regarding tree removal operations.

## **Considerations**

Tree removal operations will take into account all policies within the District Tree Strategy, particularly those defined in 2.1.3 Tree Removal and 2.7 Consultation.

## **Approval**

Trees must not be removed without the prior approval of the appointed CF officer.

## **Notification**

Residents must be notified of intended tree removals and hazard tree removals as specified by the appointed CF officer.

### 5.3 District Plan

Purpose: To provide tree removal operations whilst complying with all Council District Plan tree protection provisions.

#### Protected tree provisions

Tree removal operations must comply with the various District Council District Plan tree protection provisions and bylaws.

### 5.4 Stump Treatment

Purpose: To provide timely and safe stump removal operations.

#### Safety

Stump removal operations must be carried out in accordance with the Approved Code of Practice for Safety and Health in Tree Work, Part 1: Arboriculture, and all relevant Health and Safety in Employment Act 2002 regulations.

The Contractor will be responsible for any damages arising from stump removal operations.

Underground utility services will be located and identified by the appointed Parks Officer or when applicable the contractor, prior to stump removal operations. Stump removal debris will be removed from the site and the site must be left in a tidy and safe condition.

#### Timing

Stumps must be removed within a two-week period of the tree removal, unless otherwise specified by the Asset Officer.

#### Stump Grinding Standards

Stumps must include surface roots and must be removed to standards as listed below.

<b>Type</b>	<b>Treatment</b>
Stump removal only:	<i>Stumps shall be removed to 150mm below the surrounding soil surface.</i>
Planting of a replacement tree in the same location as the original stump:	<i>Stumps shall be sufficiently removed to facilitate the planting and establishment of a replacement tree (this may include stakes and a form of tree surround).</i>

Excess chippings must be removed from site as part of the stump removal operation. Where stumps are removed the area must be re-instated to the same standard as the surrounds. Where stumps are removed from turf areas the site must be re-instated using weed-free top soil and grass seed.

Turf areas must be re-instated level with and to the minimum standard of the surrounding ground. The methodology used to re-instate hard surfacing disturbed by stump grinding activities shall be specified by the Asset Officer.

### **Alternative Methods**

Where stump grinding is not practicable or required stumps may be removed either manually (by being dug out), cut to below ground level or treated with an appropriate herbicide, as specified by the appointed CF Officer.

Where herbicides are used these may be applied only by competent, approved operators in accordance with the manufacturers directions.

If stumps are to be treated with herbicide then care must be given to neighbouring trees, which may be root grafted to the stump (to avoid translocation). Herbicide treatment should be applied to the cambium zone within 40 minutes after the final cut has been made.

## **6.0 Debris Collection and Removal**

**Covering:**

### **6.1 Biosecurity**

Considerations  
Compliance

### **6.2 Wood Chips**

Wood chips and debris

### **6.3 Wood**

Disposal of wood

#### **Objective:**

To provide timely, safe and appropriate removal and disposal of debris associated with tree work operations.

### **6.1 Biosecurity**

Purpose: To comply with Biosecurity Act regulations in the handling and disposal of tree work debris.

#### **Considerations**

Debris collection and removal operations will take into account all policies within the District Tree Strategy particularly those defined in 2.1.2 Tree maintenance, 2.1.3 Tree Removal and 2.7 Consultation.

#### **Compliance**

Debris from tree work operations will be handled and disposed of as required under the Biosecurity Act for Dutch Elm Disease (DED) and the White Spotted Tussock Moth.

The Contractor will be responsible for liaison with the appropriate Council authority regarding disposal of debris that may pose a hazard to other plants.

## **6.2 Wood Chips**

Purpose: To re-cycle wood chips generated from tree work operations where possible.

### **Wood Chip and Debris**

All debris must be removed from sites unless otherwise specified by the appointed Community Facilities Officer.

Wood chips are required for use in Matamata-Piako District Council parks and reserves. The Contractor should transport the wood chip to such sites, for use in other maintenance tasks. The site must be left clean, safe and tidy at the end of each day.

## **6.3 Wood**

Purpose: To re-cycle or dispose of wood generated from tree maintenance operations in a safe and timely manner.

### **Disposal of wood**

Wood must be disposed of as specified by the Manager of Community Facilities, or nominated officer.

Wood may be cut into firewood lengths (30-45 cm) and left on site in some locations, as specified by the appointed CF Officer. Wood that is left on site must be left in such a way that it cannot become a hazard or damage property. (RMP 2.25 Trees and Tree Management (Policies) 10 – 17 P52-53)

## 7.0 Additional Arboricultural Operations

Covering:

### 7.1 Root zone Aeration

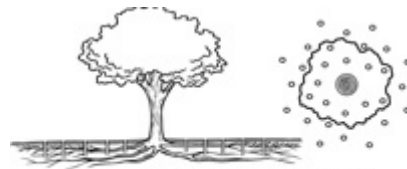

Holes drilled through the root system to improve aeration.

Figure 7.1

Alleviating soil compaction

### 7.2 Cable Bracing and Propping

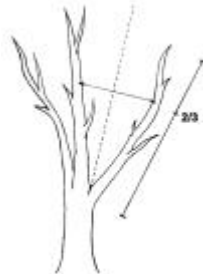

Figure 7.2

Approach to cable bracing and propping

#### Objective:

To undertake additional arboricultural operations wherever necessary, in a timely, safe and appropriate manner, whilst complying with relevant regulations and in accordance with modern arboricultural practices.

### 7.1 Root zone Aeration

Purpose: To provide aeration of compacted soils to assist with tree health.

#### Alleviating Soil Compaction

Root zone aeration must be performed as specified by the appointed CF Officer to alleviate soil compaction and break up hard soil pans where excess surface water is present.

Root zone aeration may be achieved by hand auger or compressed air injection. The intensity of treatment should not be so great that the roots of the tree will be damaged. Compressed air treatment may damage fine root hairs and should be used

in accordance with specialist advice. In some instances a granular fertiliser may be added as part of the soil aeration procedure.

## **7.2 Cable Bracing and Propping**

Purpose: To provide structural support to trees where required.

### **Approach to Cable Bracing and Propping**

Cable bracing and propping may only be carried out as specified by the appointed CF Officer.

The tree may require artificial support in appropriate circumstances in order to extend its safe life, or to lessen possible risk should the supported part collapse. Numerous cabling systems exist and caution should be exercised in the choice and installation of any one system. Personnel experienced in cable bracing and propping should determine fixing positions and materials.

All materials and workmanship must be compatible and of appropriate strength and construction to achieve the bracing safely.



## Part Three

### ***Guidelines for works within the vicinity of Trees***

#### **Introduction**

These guidelines apply to any activities that affect individual trees, groups of trees and trees found generally in areas of existing or regenerating bush under the jurisdiction of Parks and Leisure Services within the area covered by the Matamata-Piako District Council's District Plan.

The MPDC Plan objective in relation to trees is to protect trees and groups of trees that significantly contribute to the district's amenity. **There are specific rules within the tree protection provisions of the District Plan in relation to undertaking work within the dripline of a protected tree: these provisions should be considered prior to the commencement of any works.**

Trees have other important ecological, environmental and cultural attributes. They make an important contribution to the sustainable management of natural and physical resources throughout the district. Collectively they endow the rural and urban landscape with distinctive environmental quality and character.

The environmental inter-relationship between people and trees is fundamentally important. Changes in land use and building development pressures often encroach on the continued existence of trees.

With this in mind suitable guidelines are required for works within the vicinity of trees.

These guidelines are designed to give a brief overview on several key issues, including how a tree functions, how the different above and below ground parts of a tree are interdependent and how various activities may cause significant damage to trees.

Suitable mitigation measures are described in these guidelines, which will assist in deciding the best ways to provide protection to trees – in relation to both the aerial above-ground parts and, in particular, to the below-ground root systems. When prescriptive conditions are placed on work within the vicinity of trees the relevant objective of the District Plan will be achievable and sustainable.

Early consultation with the Council and a qualified arborist is also recommended.

## 1.0 How Trees Function

A tree is a dynamic living organism. All of the various parts and functions of a tree are interdependent. Understanding these parts and functions is important to prevent unnecessary damage. The trunk, crown and roots function together as a balanced system in a vigorous healthy tree. Any damage to the above or below ground tree parts will upset this balance and cause a reduction in overall tree health.

Trees are often viewed as only trunks, branches and leaves. However, a major portion of every tree, the roots, is below ground and unseen. The root system is generally overlooked and misunderstood. One of the purposes of this guide is to place importance on protecting the roots of trees.

## 2.0 Tree Parts Above Ground

### 2.1 Trunk and large branches

The trunk and branches of a tree serve three primary functions:

- Structural support
- Storage of food reserves
- Transport of essential substances.
- These functions are carried out by the various tissues which make up the trunk and branches:

Bark  
Phloem  
Cambium  
Xylem  
Sapwood  
Heartwood.

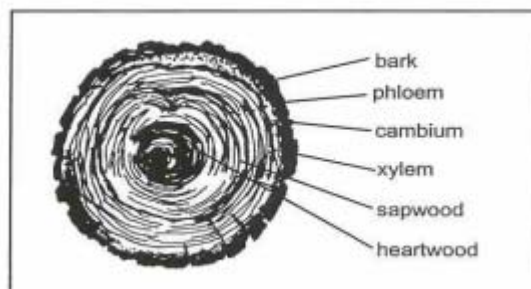

**Figure 1:**

*Cross section of a trunk or branch showing the position of each type of tissue.*

**Bark** is the protective outermost layer of tissues. Bark provides some measure of defence against physical and biological damage. It also helps moderate trunk and stem temperatures.

**Phloem** tissue is one half of the conducting vascular system located between the bark and cambium. Phloem is a series of connected cells designed to transport growth regulators, sugars and carbohydrates from the leaves throughout all parts of the tree.

**Cambium** is a sheath of actively growing cells, only a single-cell thickness. This crucial layer is continuously dividing to produce new vascular tissue which is either phloem or xylem.

**Xylem** tissues form inwards from the adjacent cambium layer, developing the other half of the vascular system. Xylem cells conduct water and essential elements from the roots to the leaves. Xylem gradually changes to become the wood of the tree. It is important in providing structural support and a volume of tissues in which to store food reserves.

**Sapwood** is the outer and active layers of wood, which provide transport, storage, structural support and protection and defence against decay pathogens.

**Heartwood** is the inner and non-conducting layers of older xylem. The main function of heartwood is to provide structural support for the tree.

**The vascular system** - that is the conductive cells which transport water and nutrients around the tree - exists just beneath the bark and is easily damaged. Any damage to the vascular system can have a serious adverse effect on tree health.

## *2.2 Tree crown*

The twigs and smaller branches of the crown (or canopy) consist of the same tissues as those in the trunk and larger branches. The branch framework is arranged in a manner that provides the maximum exposure to light for the leaves. Twigs and branches are also the primary growth sites for the buds that develop into leaves, flowers and fruits.

The growth pattern of the crown maximises the total leaf area available for the vital functions of photosynthesis (food manufacture) and respiration (gaseous exchange). Photosynthesis and respiration are the primary functions of leaves.

### 3.0 Tree Parts Below Ground

#### 3.1 Tree root functions and growth patterns

Any works process that destroys, disrupts or interferes with the normal function of the root system will have an adverse effect on the tree's health. The stability of the tree may also be compromised.

Roots serve four primary functions:

- Absorption of water and mineral nutrients
- Anchorage and stability
- Transportation of essential substances
- Storage of food reserves.

To provide these functions tree roots require a constant supply of oxygen, water, mineral elements and carbohydrates. Tree roots are opportunistic, growing wherever conditions are favourable. Available moisture and oxygen are essential to root growth.

Many people envisage roots growing down-ward at steep angles from the base of the tree trunk, extending deep into the earth. This perception of root growth is a misconception and rarely, in reality, occurs. There is variation in the extent of root spread among tree species. However, the basic growth pattern is similar for most trees. In some cases it will be necessary to protect the root system beyond the drip-line (outer extent) of the crown.

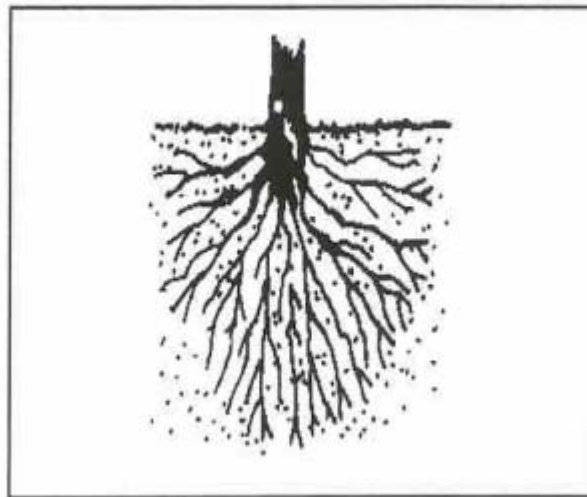

**Figure 2:**

How many people imagine tree root systems. This “mirror image” perception is completely incorrect. While a few species do have deep tap roots most do not. This notion is more artistic than accurate.

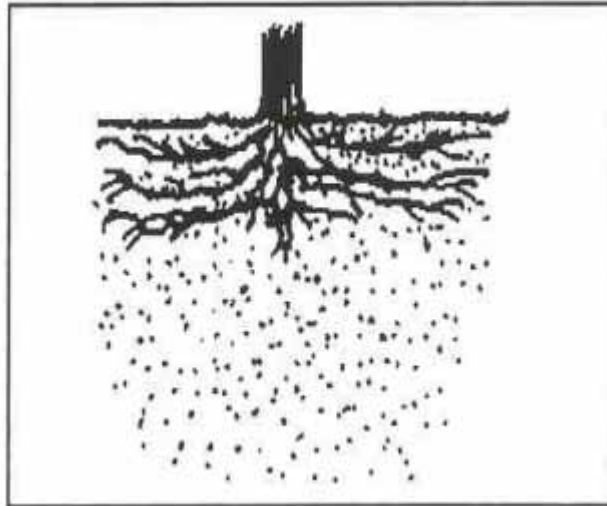

**Figure 3:**

Roots naturally spread horizontally, to where soil conditions provide nutrients and moisture. About 85% of tree roots are within the upper 500mm of soil. This figure depicts the lateral spread of roots, which is more common. Roots may spread laterally 2-3 times the height of the tree.

Under ideal conditions tree roots can extend out from the trunk two or three times the radius of the crown spread. The crown spread (dripline) is, ideally, the minimum area around a tree that should be protected.

## 4.0 Typical Root System

Typical root systems are comprised a combination of four types of roots:

- Major lateral roots
- Sinker roots
- Woody feeder roots
- Non-woody feeder roots.

**Major lateral roots** originate from the base of a tree trunk. These roots exist near the soil surface and grow outward in a radial, horizontal direction. They provide anchorage and support.

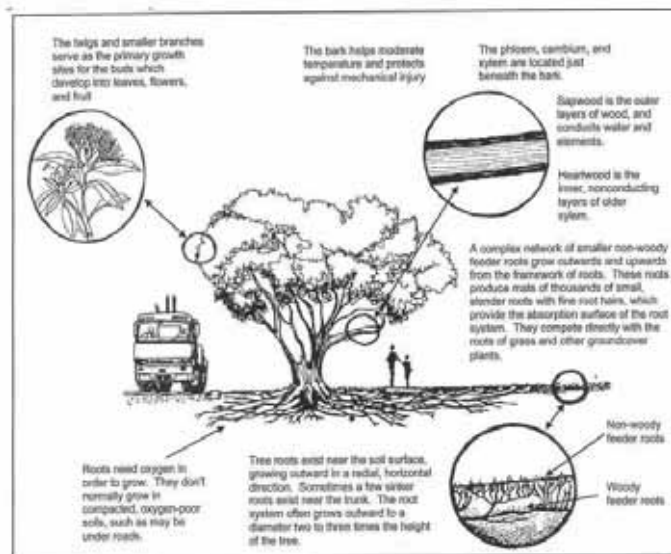

**Figure 4:**  
Parts of a tree and their primary function.

**Sinker roots** grow vertically downward from the lateral roots, providing additional anchorage and increasing the depth to which the root system penetrates. Sinker roots are usually found within a short distance of the tree trunk. Soil type has a fundamental effect upon the tree and its requirement to produce sinker-type roots.

**Major lateral roots** and sinker roots provide the primary anchorage for a tree. These roots usually do not extend below 1-2 metres in depth.

**Woody feeder roots** extend outwards from the lateral roots and are typically located in the upper 300mm of soil. They increase the area covered by the overall root system.

**Non-woody feeder roots** grow well beyond the crown drip-line. They greatly increase the absorption potential of the root system since they are very fine and net-like.

## **5.0 Wound Response**

Damage to trees, unlike damage to structures, cannot be repaired. Trees are dynamic, living organisms, but they do not heal.

Damaged tissues are not replaced and restored with new cells. Damaged areas are physically closed off from undamaged areas - by a complex chemical process known as compartmentalisation - and the damaged tissue remains within the tree for the rest of its life.

The tree's defensive reaction to wounding (and the spread of decay) - whether planned pruning or unplanned storm or construction-related damage - is to redirect energy resources. Each time a tree responds to wounding it results in a loss of energy which could have been used for healthy normal growth.

Multiple or repeated energy requirements directed to deal with wound responses may deplete the tree's total available energy reserves. Normal growth processes may be impeded. Repeated, extensive wounding can stress a tree to the point of decline.

## **6.0 Damage to Trees**

The applicant should seek advice from Matamata-Piako District Council, prior to commencing works, wherever trees will be affected by proposed land use changes or development works. Expert advice is available from the Council to ensure the health and survival of trees.

Trees are more vulnerable than many people imagine. Special care must be taken on all sites where work is to be carried out within the vicinity of trees that are to be preserved.

Damage to trees caused by construction work occurs both above and below the ground. Root systems can suffer mechanical and chemical damage. Tree trunks and crowns can be subject to various degrees of mechanical and heat damage. Such damage to trees can be serious. In many cases it is preventable and avoidable.

## 7.0 Above Ground Damage

Many construction activities cause above-ground damage to trees. Above-ground damage can result from direct impacts with construction equipment and storage of heavy materials against trees.

Trees can also be damaged by improper 'pruning' for clearance by construction personnel.

Figures 5 and 6 illustrate these points.

### 7.1 Trunk and crown damage

Trunk and branch wounding can range from minor outer bark damage to total structural failure of the main stem. Damage to the phloem, cambium and xylem disrupts the continuous flow of water, mineral elements, growth regulators and photosynthetic (sugars) between the crown and roots. The greater the circumferential damage - the greater the total amount of flow lost. Damage to wood tissues also reduces the availability of existing stored food reserves, whilst limiting the accessibility of woody tissue available for future food storage.

Trees must also redirect resources to close the large wounds, adding to the net energy loss. The exposed wood tissues at wounds provide open access for wood rotting fungi. Trees stressed or weakened by construction damage may also be predisposed to secondary insect and disease infestations.

When large branches are torn way from trees the damage is substantial. Loss of major limbs reduces the quantity of leaf area, thereby reducing the tree's total photosynthetic (sugar) production.

Total leaf area is also reduced by leaf scorch and twig death. This occurs when hot exhaust gases vent from equipment operating beneath tree crowns.

Heat and fumes can kill or injure the tree's trunks, branches and leaves - reducing its capacity to survive.

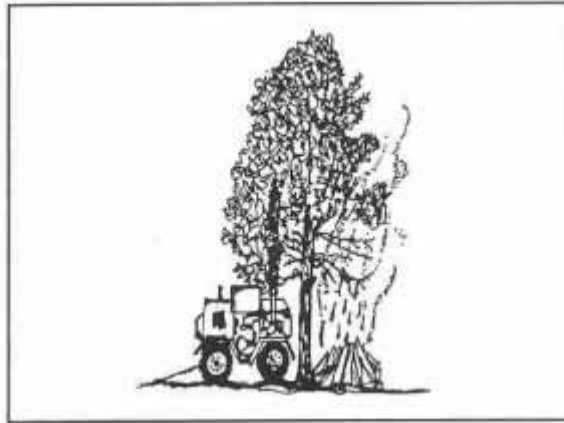

**Figure 5:**

Keep all construction equipment, generators and static machinery well away from tree branches. Do not light fires or create any source of heat or noxious fumes within the branch spread.

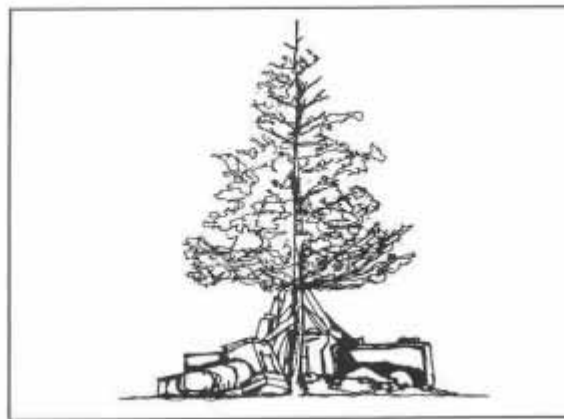

**Figure 6:**

Do not put soil, debris, or any construction materials against tree trunks or within the root zone.

## 8.0 Below Ground Damage

Tree roots often suffer extensive injury and loss as a result of construction work. The main causes of construction damage below ground are:

- Soil compaction
- Direct root loss
- Soil grade changes
- Chemical contamination.

### 8.1 Soil compaction

The soil within the root zone of a tree may become compacted from the weight of general construction traffic, the operation of heavy equipment and by the storage of construction materials within the root zone. The soil may also be intentionally compacted as an engineering requirement of construction.

Soil compaction changes soil structure by squeezing out air. The effect is an increase in bulk density, or solidity. Compaction decreases soil-borne oxygen, which is necessary for root respiration, and increases the accumulation of carbon dioxide and other toxic gases. It also restricts the filtration of water. See Figure 7.

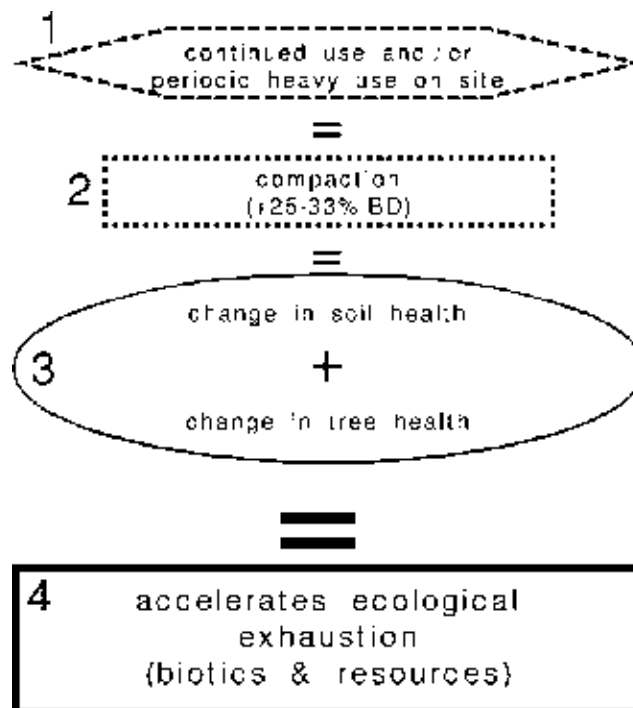

**Figure 7**  
**Compaction effects**

Compaction will affect water filtration by making some soil types more impervious, whilst others may retain more water. Compaction invariably leads to either the drying or water-logging of soils surrounding tree roots. Such changes in soil moisture can cause direct root mortality.

Abnormal soil moisture and compacted soil structure can also prevent roots growing and extending in to new areas. Symptoms of compaction are not usually immediately obvious and trees may die several years after compaction damage has occurred.

Apparently healthy trees growing in areas covered by impervious materials (such as concrete or asphalt) have usually grown under such conditions since they were saplings. Mature trees may be killed by new surfacing.

Seek the advice of a qualified arborist before installing hard surfaces over the root system of any notable or protected trees.

### *8.2 Direct root loss*

Excavating and trenching machines are commonly used in construction. This equipment has the potential of causing extensive root loss when no concern is given to root systems during trenching and excavating activities.

Roots can be severed, torn away or crushed causing serious wounding and loss of normal structural stability. This can lead to direct tree mortality and/or uprooting. Less severe damages may lead to drying out and death of exposed roots. Roots that are badly damaged are prone to decay pathogens. The physical loss of roots will affect the tree's stability and ability to survive and may lead to a decline in tree health.

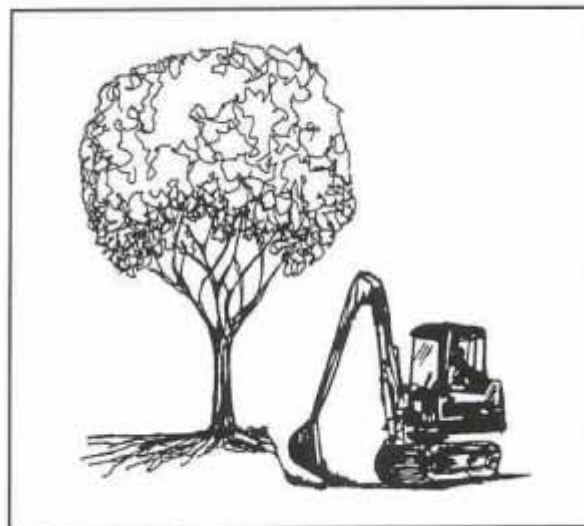

**Figure 8:**

Do not trench or excavate within the root zone of trees - this may damage or sever roots.

### 8.3 Soil grade changes

Levelling, filling and cutting of soil grades will result in the same types of damage associated with excavating, trenching and soil compaction. Grading may also remove the nutrient-rich topsoil which supplies the basic nutrients and elements that trees require for growth. See Figure 8.

Lowering or cutting grades can remove a large percentage of feeder roots. Raising or filling grades around trees reduces air diffusion and exchange in the root zone. As little as 100mm of soil placed over the established root systems of some species is enough to kill them.

Even if grade changes are not made directly in the root zone they may be close enough to root systems to affect water drainage. This may cause root dieback due to changes in soil moisture content.

### 8.4 Chemical damage

Leaking or spilling of fuel, lubricants or hydraulic oils, or intentional dumping of masonry resinates, paints, acids, solvents, or any other toxic substances may kill roots or impede their functions. When such toxins are deposited in tree root zones they adversely affect tree health or directly cause tree mortality. See Figure 9.

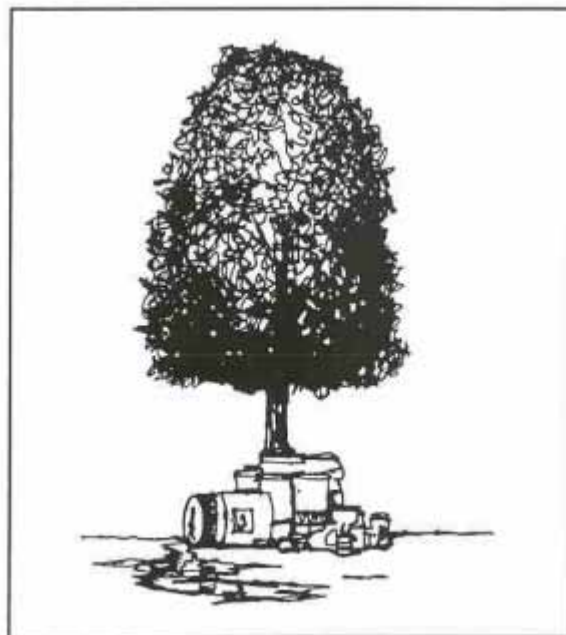

**Figure 9:**

Do not store or dispose of any toxic substances within the root zone.

## **9.0 Tree Protection and Care**

Trees require protection on the work site by excluding all construction operations from a defined exclusion area around them.

The success of the tree protection process will depend on the co-operation of all persons involved in the design, construction and implementation of the protective measures.

It is essential for those involved in the site works to appreciate the need for maintaining the area of protection around trees. Breaching the protective zone can easily waste the time, effort and expense that has gone into the protection of the trees.

## **10.0 Protective Fencing**

Before any materials or machinery are brought on site, or prior to commencement of any demolition or development, protective fencing must be erected around all trees that are to be retained. Trees on adjacent properties affected by the construction works must also receive appropriate protective fencing. See Figure 10.

The fencing must be strong and appropriate to the degree of construction activity taking place on the site.

The protected area around trees must be of dimensions recommended in Figure 11. The temporary fencing around this area must be maintained throughout construction works. The temporary fencing should be 1.8 - 2m high and must prevent access within the protected area.

No works may be carried out within the protected area. No materials may be stored within the protected area.

Notices should be erected on the fencing with words such as "Protected area - no operations within fenced area".

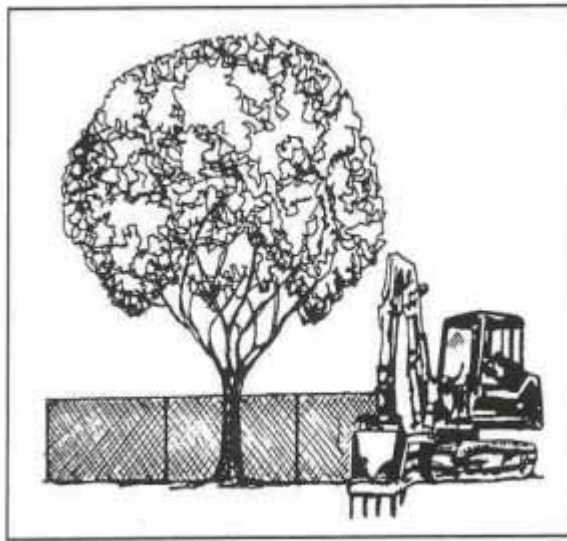

**Figure 10:**  
Protective fencing must be strong and appropriate to the level of construction activity taking place on site.

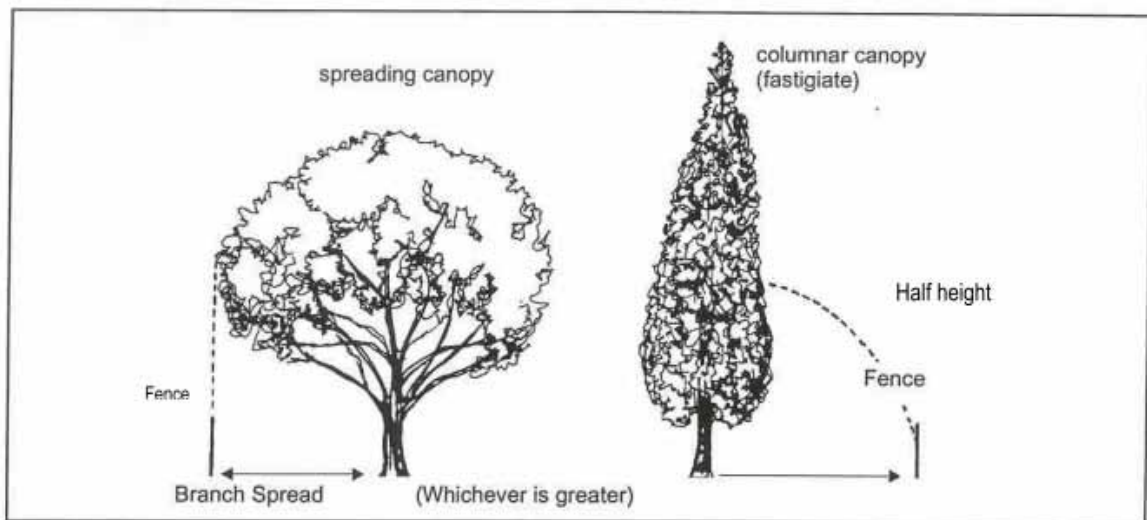

**Figure 11**  
Dimensions for locating perimeter fencing

## **11.0 Installation of Utility Services**

Detailed plans area required to show the routing of all services in the proximity of trees. Plans must indicate the area needed for installation of the services.

Care is also needed in routing above-ground services to avoid any excessive pruning requirement before or after the installation of services.

If an alternative route can not be used then the installation of underground services must be done in a way that minimises damage to trees - for example using techniques such as thrusting and/or hand digging.

Open cut trenching can cause major damage to tree roots, as shown in Figure 12a. Thrusting minimises and localises damage to tree roots, as shown in Figure 12b and is the preferred method of service installation.

### **11.1 Thrusting and directional drilling**

Traditional methods of service establishment (ie. open cut trenching) can cause massive root damage and ground disturbance. The resulting 'change of environment' for the tree will be substantial.

The action of 'thrusting' or 'directional drilling' is the most preferred method of service establishment within the drip-line of trees. When these two methods are used the 'change of environment' around the tree is minimised.

All machinery and starting pits associated with the action of thrusting or directional drilling should remain outside the drip-line of trees. This is to minimise any root loss or ground compaction that may arise from the works.

If the thrusting rod or directional drill head becomes stuck underneath the drip-line of a tree then the arbourist responsible for the trees on the site should be contacted prior to the retrieval process. Any retrieval of a thrusting rod or directional drill-head beneath the drip-line of a tree should be undertaken with hand tools unless otherwise stated by the arbourist responsible for the trees on the site.

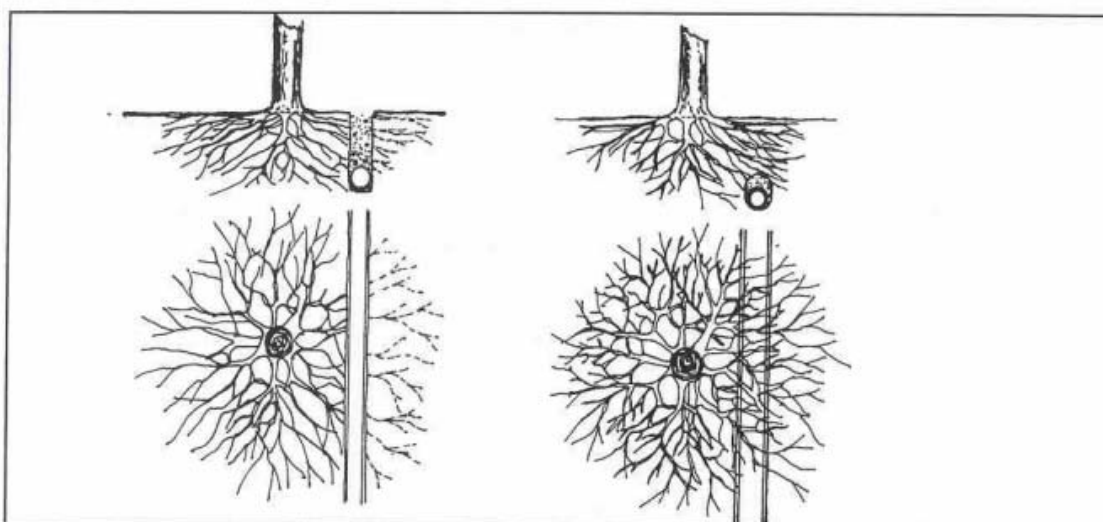

Figure 12a: Trenching causes major damage.

Figure 12b: Thrusting minimises damage.

## 11.2 Hand digging

The excavation method of 'hand digging', if carried out correctly, has the potential to have 'no more than minor' effects on the health and safety of the tree(s) that are within the line of works.

The objective of hand digging is to retain the majority of roots. Great care should be taken when hand digging within, or close to, the drip-line of a tree. Works should be undertaken with due care and attention. The more time and care spent on hand digging the less impact the work will have on the health and safety of the tree.

The main motivation for using hand digging as a method of excavation is root retention.

When digging within the drip-line of a tree carefully remove the soil, making sure that any roots accidentally discovered are not repeatedly hit or severed. Take care not to damage the outer 'bark' of roots, as this is the area where the transport of nutrients and water to the rest of the tree occurs.

Fact: Hand digging takes time. Allow enough time for this method of works to occur when planning works. If a substantial amount of hand digging is required on your site consider training up a specialist crew who will become skilled in this method of excavation and, therefore, reduce the time that is required to achieve the work.

The majority of the roots are usually found near the soil surface. It may be possible to excavate by hand to a certain depth and then, in the absence of any roots that are to be retained, excavation by another method may be possible. Prior to the work occurring seek advice from the arborist responsible for the trees on the site as to how to proceed with the method of hand digging.

## Part Four

### Appendices

#### Appendix 1 Trees that should be excluded from road reserves

Botanical Name	Common Name
<i>Paraserranthes lophantha</i>	Brush Wattle, Albizza
<i>Casuarina sp</i>	She-Oak
<i>Cupressocyparis leylandii</i>	Leyland Cypress
<i>Chamaecyparis lawsoniana</i>	Lawsons Cypress
<i>Cupressus macrocarpa</i>	Monterey Cypress
<i>Eucalyptus cinerea</i>	Silver Dollar gum
<i>Ligustrum ovalifolium</i>	Privet
<i>Pinus radiata</i>	Monterey Pine
<i>Populus sp</i>	Poplar
<i>Salix sp</i>	Willow
<i>Berberis sp</i>	Barberry
<i>Solanum mauritianum</i>	Woolly Nightshade
<i>Juglans sp</i>	Walnut
<i>Cotoneaster sp</i>	Cotoneaster
<i>Euonymus japonicus</i>	Japanese Spindle Tree
<i>Cornus capitata</i>	Strawberry Tree
<i>Acer pseudoplatanus</i>	Sycamore
<i>Syzygium smithii</i>	Monkey Apple
<i>Acacia dealbata</i>	Silver wattle
<i>Cyathea medullaris</i>	Black Ponga

## **Appendix 2 Guide to consider the request for tree removal**

### **(or pruning work that exceeds regular maintenance requirements):**

- The interests of the public in the maintenance of an aesthetically pleasing environment,
- The desirability of conserving public reserves containing trees,
- The value of the tree as a public amenity, including shade contribution.
- The historical, cultural or scientific significance (if any) of the tree,
- The botanical significance of the tree,
- The contribution of the tree to the ecology of the area, including significance as habitat for native fauna,
- Whether the tree or treescape contributes to a landscape of regional or national significance and/or a landscape designed with public consultation,
- The contribution of the tree(s) to the medium to long term vision of a reserve management plan or streetscape,
- Whether the requested works constitute good arboricultural practice, and
- The impact of the tree (positive or negative), at that location on adjoining properties, including impact on amenity values.

### **If the tree:**

- Is dead, dying, diseased, decayed or disfigured with no realistic chance of recovery.
- Presents an immediate or potential danger to people or property, or is shown to be potentially a severe health or safety risk to neighbouring residents as identified by the ISA Tree Hazard Evaluation Method.
- Is causing uncontrollable structural damage to any street or utility service and remedial work to prevent further damage is impractical or greater than the value of the tree.
- Is encroaching into the carriageway in such a way that visibility is reduced or clearly causing a significant hazard and remedial work cannot mitigate the hazard without severely disfiguring or otherwise compromising the health or aesthetic qualities of the tree.
- Is inhibiting the proper management or maintenance of the reserve or other Council land
- Is inhibiting the growth, development or health of other trees of greater value.
- Is deemed to be of low amenity value and is poorly sited or requires unduly high maintenance (such as in a location which conflicts with services).
- Is unsustainable i.e. is unsuitable for the site due to its long term potential to cause problems or the inappropriateness of the species in relation to the site.
- Is recognised potential. As a species with high weed dispersion was planted for revenue producing purposes and is, as a result, being harvested.

## Appendix 3 Profile and Street Tree Selection Criteria

### *Profile and Street Tree Selection Criteria*

The process for the selection of trees for planting on Council land is based upon the following criteria:

#### **1. Site suitability to existing environmental conditions:**

Will the species tolerate the site?

1 = Will not do well

10 = Adapts well to wind, salt, exposure

#### **2. Rate of establishment:**

How practical is it to establish the species in this environment?

1 = Hard or slow to establish

10 = Establishes easily and quickly

#### **3. Longevity:**

Is it a long term or short term species?

1 = Short term less - than 40 years

10 = Long term - more than 40 years

#### **4. Impact on the landscape:**

What sort of impact does the species create, in terms of scale and suitability in the long term?

1 = Small scale or minimum impact

10 = Large scale or bold impact

#### **5. Compatibility with established themes:**

Does the species 'fit in' to the established theme for the area?

1 = Looks out of place with existing character 10 = Reflects local character and theme

#### **6. Manageability:**

Is the species easy to manage?

1 = Difficult to manage

10 = Easily managed

#### **7. Availability of stock:**

Is plant material available?

1 = Hard to source or expensive

10 = Readily available - reasonable cost

#### **8. Form:**

Does the species have manageable form?

1 = Unpredictable or inconsistent form

10 = Predictable and manageable form

**9. Undesirable characteristics:**

Does the species have particular problem habits, such as messy fruits, excessive leaf litter?

1 = Has some or many problem habits

10 = Has few problem habits

**10. Amenity values**

Does the species have attractive/interesting/colourful characteristics?

1 = Has low amenity values

10 = Has high amenity values

**Note:** to be accepted a tree must:

- (a) Score 7 or more out of 10 for item 1; and
- (b) Score 6 or more out of 10 for all other items; and
- (c) Score a minimum of 61 points out of a possible 100 points.

## Appendix 4 Species Selection

Species selection is the most important aspect of the greening of streets. Final selection of species should only be made after all the problems relating to overhead and underground utility services and berm widths have been finalized

To select species without consideration of these aspects will set up future ratepayers for ongoing costs and compromise the long term prospects of roadside plantings. Correct selection for the site will result in minimal tree maintenance and other works costs. The checklist of criteria for selection of the tree species should include:

### *Physical Characteristics*

**Height at maturity**  
**Width at maturity**  
**Shape of canopy**  
**Buttressing – above ground root system**

<p><b>Root system</b> Size          Type of roots          System shape          Regeneration capacity          Tendency to invade underground services</p> <p><b>Leaves</b>          Size          Decomposing ability          Colour          Texture          Quantity          Deciduous or evergreen nature</p> <p><b>Flowers</b>          Size          Decomposing ability          Colour          Smell          Nectar/pollen          Quantity</p> <p><b>Fruit</b>          Size          Decomposing ability          Colour          Smell          Quantity</p>	<p><b>Problems</b>          Allergy rating          Poison rating          Spikes          Branch drop          Suckering ability          Tendency to produce multiple stems          Roots in drains/sewers          Shading ability          Tendency to require pruning</p> <p><b>Amenity Characteristics</b>          Visual appropriateness          Relationship to nearby plantings          Relationship to local heritage if applicable          Relationship to neighbours          Longevity</p> <p><b>Site Factors</b>          Soil type          Drainage          Prevailing wind          Presence of foreign materials in root zone          (e.g.: bricks, concrete, rubbish)</p>
--	--

**Bark**

Decomposing ability

Colour

Texture

## Appendix 5 Wilful Damage to Council Trees



To respond in a consistent manner to the wilful damage of Council trees, in order to deter future offences of this nature and to take appropriate action according to New Zealand law.

### Notification of Wilful Damage to trees or property

To The Matamata-Piako District Council  
C/- Community Facilities Manager  
PO BOX 266  
Te Aroha

I /we \_\_\_\_\_

of (address) \_\_\_\_\_  
\_\_\_\_\_

Area where damaged occurred (e.g. which street or park)  
\_\_\_\_\_

Did you see the actual offense take place YES / NO

Did you report this to the Police YES / NO

Can you give details of the damage and any information that may assist in bringing the offenders to justice?

\_\_\_\_\_  
\_\_\_\_\_  
\_\_\_\_\_  
\_\_\_\_\_  
\_\_\_\_\_

Your information will remain confidential and should we require further clarification of the information that you have given, may we contact you.

Are you willing to assist us as a witness should we bring a prosecution

## Appendix 6 Tree Removal

To ensure that consistent criteria are applied when considering the removal of Council trees for the purposes of Council initiated works.

To ensure that consistent criteria are applied when considering the removal of Council trees in response to a request for service from a member of the public.

1. The interests of the public in the maintenance of an aesthetically pleasing environment,
2. The desirability of conserving public reserves containing trees,
3. The value of the tree as a public amenity, including shade contribution.
4. The historical, cultural or scientific significance (if any) of the tree
5. The botanical significance of the tree,
6. The contribution of the tree to the ecology of the area, including significance as habitat for native fauna,
7. Whether the tree or treescape contributes to a landscape of regional or national significance and/or a landscape designed with public consultation,
8. The contribution of the tree(s) to the medium to long term vision of a reserve management plan or streetscape, and
9. Whether the requested works constitute good arboricultural practice, and
10. The impact of the tree (positive or negative), at that location on adjoining properties, including impact on amenity values.

# Request for tree Removal



To The Matamata-Piako District Council  
C/- Community Facilities Manager  
PO BOX 266  
Te Aroha

I /we \_\_\_\_\_

of (address) \_\_\_\_\_

\_\_\_\_\_

Request that permission be given for the removal of a tree/ or trees at

\_\_\_\_\_

Reason for removal is:

\_\_\_\_\_

\_\_\_\_\_

\_\_\_\_\_

Species for removal and other comments

\_\_\_\_\_

\_\_\_\_\_

\_\_\_\_\_

\_\_\_\_\_

Signed: \_\_\_\_\_ Date: \_\_\_\_\_



## Appendix 7 Tree Planting

Council tree planting will ensure the existing distinctive landscape characters of the district are reinforced, using species that are appropriate to the location and site (may be native, exotic or a mixture).

To plan future plantings to minimise costs and potential for problems with services, assets, properties and infrastructure in the short and long term.



# Request for Tree Planting



To The Matamata-Piako District Council  
C/- Community Facilities Manager  
PO BOX 266  
Te Aroha

I /we \_\_\_\_\_

of (address) \_\_\_\_\_

\_\_\_\_\_

Request permission the planting of a tree/or trees at

\_\_\_\_\_

Reason for planting is:

\_\_\_\_\_

\_\_\_\_\_

\_\_\_\_\_

Species requested and other comments

\_\_\_\_\_

\_\_\_\_\_

\_\_\_\_\_

\_\_\_\_\_

Signed: \_\_\_\_\_ Date: \_\_\_\_\_



## Appendix 8 Guide for developers

### *Planning and management of trees treescape and other significant types of vegetation during subdivision and other types of development*

#### **District Plan provisions related to trees and development:**

The current Matamata-Piako “**District Plan**” contains regulatory and non-regulatory provisions for the protection and maintenance of trees, treescapes and significant vegetation on both public and private land. (Part A Section 3 Environment 3.1, 3.4, 3.9 Part B 1 general provisions, 6 Subdivision, 10 Natural Heritage and environment).

The subdivision consent process under the Resource Management Act (1991) provides opportunity to assess vegetation on development sites and to attempt to retain or work around trees, treescapes and significant vegetation identified to be of significance. In many cases an assessment will identify vegetation of little significance that may be removed in exchange for retention of any significant trees, treescapes and significant vegetation on the site or mitigation by replacement trees. The intention is not to place unrealistic expectations on the developer to retain vegetation of little value, but to provide assistance on how best to integrate the urban design and any significant vegetation on the site.

## Objectives and Policies from the District Tree Strategy Matamata-Piako District Council

### Objective

To ensure appropriate consideration of, and planning for, trees and treescapes during the design and consent process for resource consents

### Policy 1

Council officers will work with resource consent applicants to identify opportunities to plant or retain trees, treescapes and significant vegetation during the design and consent process.

Considerations will include:

- Centre islands or median strips wide enough for planting (minimum 2m and as appropriate to the species planted).
- Wider grass berms. (minimum of 1.5 m if tree landscaping proposed).
- The inclusion of root barriers
- The inclusion of rain garden concepts within new development or where existing developments are being altered. Recommendation for plants in this concept are tabled in Appendix 12

(Also refer to Development Manual and Applicable Engineered Stormwater Devices Contained in the Auckland City publication TP10 Stormwater Management Devices: Design Guidelines Manual for in-depth definitions of engineered stormwater devices. Examples of devices that require a landscaping component are as follows)

Design layout to include the protection and enhancement of significant trees, treescapes and significant vegetation with the development

The use of “set backs”, all urban areas to provide space for tree canopies to develop.

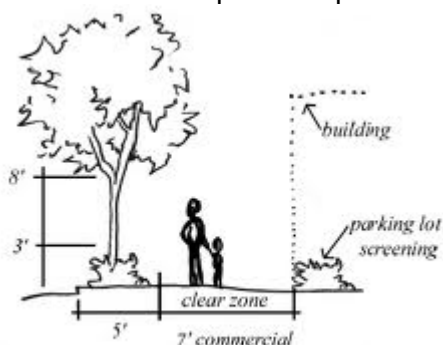

Street trees located between the walking route of the sidewalk and curb edge

Maintaining road safety and activity clearance, including:

- Minimum 3 m from vehicle access ways (e.g., driveways),
- Minimum 1.5 m from underground services, and
- Minimum 5m from overhead services and/or compliance with the Electricity (Hazards from Trees) Regulations 2003.
- Minimum 8 m from any light stand
- Minimum of 6m from any intersection
- 5 m from any bus stop, or school speed sign

#### Policy 2

In general, tree, treescapes and significant vegetation will be sought for developments that create new roads or wherever new public land is created as an outcome of the resource consent and where re-development occurs.

#### Policy 3

Community Facilities Staff or an appointed agent will assess development proposals, upon requests from MPDC Planning and offer advice on opportunities to plant new trees, treescapes and significant vegetation or to maintain existing trees, treescapes and significant vegetation prior to formalising the development concept.

NOTE: This service may incur a cost

#### Policy 4

Council will work together to promote the long term health of existing, future and protected trees, treescapes and significant vegetation within Council and private lands as an outcome of development design and planning. This includes recognition of the importance of root zones to tree health and the need to manage for tree health below-ground as well as above-ground.

#### Policy 5

Council will work together to ensure that existing and future trees, land or trees that are administered by the Council are included in development designs in consideration of their proximity to, and likely effect on, above or below ground infrastructure as well as ecological implications.

#### Policy 6

Council will provide incentives to encourage developers to adopt the Code of Landscape Design and Practice. These could include:

- Providing recognition, in the form of awards and other publicity, for developments that meet or exceed the Code.
- Providing advice on the appropriate species to plant in the location and design.
- Promoting incremental value to a development as a result of providing an attractive landscape design that includes existing and new trees. This includes providing habitat for easily recognised and popular bird species such as tui and kereru.

#### Policy 7

Council will undertake education and promotion work to increase awareness and understanding of the values and benefits of trees, treescapes and significant vegetation (as outlined in section 1.4.2), the requirements for long-term tree health, ways to incorporate trees, treescapes and significant vegetation into a development plan and plant species for street site character areas Target audiences could include developers, surveyors and realtors.

#### Policy 8

Developers are required to access the value of existing mature trees, treescapes and significant vegetation onsite and to design their development to protect and enhance those features.

#### Policy 9

Developers are required to incorporate significant trees, treescapes and significant vegetation within their development design to ensure that shade or views do not become an issue with subsequent landowners

### Explanation

The MPDC Code of Landscape Design and Practice (CLDP), and Urban Design Principles once completed, will set the standard for developments in the district. The CLDP will provide technical guidelines on appropriate tree and site selection and preferred infrastructure design to ensure attractive and functional landscapes over the long term.

The Urban Design Protocol (found at <http://www.mfe.govt.nz/issues/urban/design-protocol/>) identifies seven essential design principles:

- **Context:** Seeing that buildings, places and spaces are part of the whole town or city
- **Character:** Reflecting and enhancing the distinctive character, heritage and identity of our urban environment
- **Choice:** Ensuring diversity and choice for people
- **Connections:** Enhancing how different networks link together for people
- **Creativity:** Encouraging innovative and imaginative solutions
- **Custodianship:** Ensuring design is environmentally sustainable, safe and healthy
- **Collaboration:** Communicating and sharing knowledge across sectors, professions and with communities.

One of the most effective methods of ensuring appropriate consideration of trees and treescapes during development is to increase awareness and understanding of the values and benefits of trees and the importance of the “right tree in the right place”.

The additional benefit of careful proactive planning for treescapes during developments is that future conflicts over adjacent trees, due to shade or interruption of views, can be mitigated.

## *Resource Consent Applicants*

### **Design guidelines**

#### **Treescape**

##### **Wide Avenue and open spaces - Large trees**

- Use where wide berms allow
- Main thoroughfares
- Entranceways to estates or subdivisions
- See suggested lists Appendix 9

##### **Smaller streets - Smaller species**

- Use within the residential street confines
- Retain character of town
- Introduce natives
- See suggested lists Appendix 9

##### **Computer Modeling**

- Have proof of shade effects
- Have proof of tree sizes at 5, 10, 15, 20 year periods.
- Information on litter, fruit etc effects
- See suggested evaluation criteria Appendix 3 & 4

##### **Environmental Effects**

- Maintenance
- Services and utilities
- Flora and Fauna
- Health and safety

## Appendix 9 Planting Guide for Residential Sections

This is a guide only but assigned to give the best results with the least impact on future maintenance, services and undesirable effects on the residential property.

### *Species Selection*

Species selection is the most important aspect of residential tree selection. Final selection of species should only be made after all the problems relating to overhead and underground utility services and impact on buildings have been finalised.

Correct selection for the site will result in minimal tree maintenance and other costs. The checklist of criteria for selection of the tree species should include:

### *Physical Characteristics*

**Height at maturity**  
**Width at maturity**  
**Shape of canopy**  
**Buttressing – above ground root system**

<p><b>Root system</b>          Size          Type of roots          System shape          Regeneration capacity          Tendency to invade underground services</p> <p><b>Leaves</b>          Size          Decomposing ability          Colour          Texture          Quantity          Deciduous or evergreen nature</p>	<p><b>Problems</b>          Allergy rating          Poison rating          Spikes          Branch drop          Suckering ability          Tendency to produce multiple stems          Roots in drains/sewers          Shading ability          Tendency to require pruning</p> <p><b>Amenity Characteristics</b>          Visual appropriateness          Relationship to nearby plantings          Relationship to local heritage if applicable          Relationship to neighbours          Longevity</p> <p><b>Site Factors</b></p>
--	---

<p><b>Flowers</b> Size Decomposing ability Colour Smell Nectar/pollen Quantity</p> <p><b>Fruit</b> Size Decomposing ability Colour Smell Quantity</p> <p><b>Bark</b> Decomposing ability Colour Texture</p>	<p>Soil type Drainage Prevailing wind Presence of foreign materials in root zone (e.g.: bricks, concrete, rubbish)</p>
---	--

People tend to plant trees that become too large for the site when they reach maturity. Seek advice if you are not sure. Matamata-Piako District Council Community Facilities have qualified staff to help.

Most problems come from the trees being too large when mature causing problems of shading, leaf litter and encroaching onto neighbours property.

In some varieties such as maples there are a large number which are compact give a beautiful shape and colour but do not cause the problems of the larger trees of that species.

On the standard size section of between 600 and 900 square metres large trees such as *Ginkgo biloba* Maiden hair tree *Fagus* Copper Beech, Liquidambar, Liriodendron (tulip tree but not related to Magnolias), *Quercus* Oaks, elms as an example should not be considered.

Most New Zealand natives such as *Sophora* "Kowhai" *Agathis australis* "Kauri", *Prumnopitys ferruginea* "Miro or Brown pine", *Dacrydium cupressinum* "Rimu" give the least amount of problems, and can be arranged to give screening, colour, texture and bring back the birdlife.

The following lists give the common names and size at maturity

## Trees

Common Name	Size at maturity Height x width	Recommended for sections
<i>Acer x freemanii</i> Freeman maple'	13 x10	Yes Minimum 4 metres from buildings and boundaries
<i>Acer plantanoides</i> Norway maple	15 x12	No
<i>Acer palmatum</i>	various	Yes
<i>Acer rubrum</i> Red maple	13x9	Yes Minimum 4 metres from buildings and boundaries
<i>Acer saccharinum</i> Silver maple 'Skinner'	20x15	No
<i>Aesculus hippocastanum</i> Horsechestnut	18x10	No
<i>Betula papyrifera</i> Paper birch	13x10	Yes Minimum 4 metres from buildings and boundaries
<i>Betula pendula 'Gracilis'</i> Cutleaf weeping birch	13x10	Yes Minimum 4 metres from buildings and boundaries
<i>Carpinus betulus '</i> Common hornbeam	8x6	Yes Minimum 4 metres from buildings and boundaries
<i>Carpinus betulus 'Fastigiata'</i> Columnar hornbeam	8x6	Yes Minimum 4 metres from buildings and boundaries
<i>Carpinus Japonica</i> Japanese hornbeam	15x10	No
<i>Castanea Sweet Chestnut</i>	20x18	No
<i>Catalpa speciosa</i> Northern catalpa	12x8	No
<i>Cercis Redbud, judas,</i> <i>foresrt pansy</i>	4x2.5	Yes
<i>Cornus Dogwoods</i>	Between 4 to 6 x 3	Yes
<i>Corylopsis Winter hazel</i>	2x1	Yes
<i>Corylus Hazel</i>	3x2	Yes
<i>Cotinus Smoke bush</i>	Between 3 and 5 x 2.5 to 3	Yes
<i>Diospyros Persimmon</i>	Up to 15 x10	Yes
<i>Fraxinus Ash</i> 'Autumn Purple'	9x7	Yes Minimum 4 metres from buildings and boundaries

<b>Common Name</b>	<b>Size at maturity Height x width</b>	<b>Recommended for sections</b>
<i>Fagus Beeches European</i>	Range from 3 to 15 metres	No
<i>Fraxinus nigra</i> Black ash	12x9	No
<i>Ginkgo biloba Maiden hair tree</i>	8x4	Yes Minimum 4 metres from buildings and boundaries
<i>Gleditsia honey locustermis</i> Thornless honeylocust	7x5	Yes Minimum 6 metres from buildings and boundaries
<i>Griselinea littoralis</i>	3x2	Yes
<i>Griselinea Lucida</i>	3x2	Yes
<i>Lirodendron Tulipifera</i> Tulip tree	20x15	No
<i>Lirodendron Tulipiferum</i> Fastigata Tulip tree upright	10x8	No
<i>Lirodendron Tulipiferum</i>	6x3	Yes Minimum 4 metres from buildings and boundaries
<i>Magnolia</i>	From 2 to 15	Y selected small varieties only
<i>Malus crab apples</i>	3 to 5	Yes
<i>Michelia</i>	2 to 8	Yes
<i>Olea Olive</i>	6 to 8	Yes
<i>Pittosporum Tenafolium</i>	3 to 6	Yes
<i>Pittosporum Eugenioides</i>	5 to 10	Yes Minimum 4 metres from buildings and boundaries, Some varieties are very good for hedging where there is no intrusion on neighbours
<i>Platanus Plane tree</i>	15 x12	No
<i>Podocarpus Totara</i>	20x7	No
<i>Prunus Flowering cherries</i> <i>almonds, apricots &amp; plums</i>	2 to 4 metres	Yes
<i>Prunus Evergreen</i> <i>lusitanica Portugese laurel</i>	5x4	Yes
<i>Pyrus Ornamental Pears</i>	10x8 or height according to standards	Yes Minimum 4 metres from buildings and boundaries

<b>Common Name</b>	<b>Size at maturity Height x width</b>	<b>Recommended for sections</b>
<i>Quercus bicolor</i> Swamp white oak	20x18	No
<i>Quercus palustris</i> Pin oak	20x15	No
<i>Quercus robur</i> English oak 'Fastigata'	20x15	No
<i>Quercus rubra</i> Red oak	20x15	No
<i>Sophora japonica</i> Japanese pagodatree	10x15	Yes Minimum 4 metres from buildings and boundaries
<i>Sophora kowhai</i>	10x7	Yes Minimum 4 metres from buildings and boundaries
<i>Sophora Dragons gold</i>	3x2	Yes
<i>Sophora Prostrata</i>	4x.500	Yes
<i>Tilla cordata</i> Linden or Lime	5x3	Yes
<i>Tilla cut leaf lime</i>	12x9	No
<i>Ulmus glabra</i> Horizontal or weeping elm	Produced on standards	Yes
<i>Ulmus Hollandica</i> Groenveld	20 height conical form	No
<i>Ulmus golden/Siberian</i> Chinese	All 6x4	No
<i>Ulmus carpinifolia</i> Variegata Elm	6x4	Yes Minimum 4 metres from buildings and boundaries

## Appendix 10 Your Rights - Trees, Fences and Your Neighbours

Disputes over trees and fences are a common cause of ill feelings between neighbours - trees that block your sun, roots that choke your drains, fences that your neighbours want built or replaced - often at considerable expense. Your differences can usually be settled by talking to your neighbours and coming to a compromise. If you are forced into a stand-off, legal action may be your only option. This could cost you anywhere from hundreds to thousands of dollars and could destroy neighbourly goodwill.

### Trees

Sections 332 to 338 of the Property Law 2007 provide property owners with legal remedies where their neighbour's tree presents an actual or potential risk to life, health, property or obstructs your view.

These remedies are only available through an order made by the District Court, so you need to decide first whether the nuisance is worth the risk of damaging your relationship with your neighbour. Try to work out a thoughtful solution first. Your neighbour may be happy to help you with any work that needs to be carried out because of their tree/s.

If you can't come to a compromise you may have to go ahead with legal action. You will need to ask your lawyer to organise an application for a court order. If your application is successful, the District Court will send a notice to your neighbour ordering action to be taken within a set time or they will have to appear in court. They can order a tree or any part of it, to be removed or trimmed in order to prevent the risk or nuisance that it is creating.

If the roots or branches of your neighbour's tree encroach on your land, you can cut them back to the boundary line. If you are cutting out part of the tree's roots or branches take care not to damage the health and stability of the tree or the ground around it.

When cutting back branches you must not do any more work than is necessary and no damage should result from your actions. You should not trespass on your neighbour's property or create any other problems for your neighbour. You must not poison the roots or spray the tree with herbicide, as the consequences would extend beyond your property.

Cuttings and fruit belong to the tree owner. If these end up on your property you can either put these back on your neighbour's property, taking care not to cause any damage, or ask your neighbour to remove them. If the trunk of the tree extends over the boundary, this does not give you the right to cut it down. If the tree is planted on the boundary, you are probably a co-owner.

If you have incurred costs from cutting back the roots and branches on your side of the boundary, you will probably not be able to claim them back from the tree owner.

But if the roots of your neighbour's tree have damaged your drains or a branch falls on your house, they may have to pay the costs of fixing up the problem as well as any compensation that may be owed.

If trees on a neighbour's property are blocking sunlight or views from your house and garden then you may be able to take legal action. To take legal action you will have to convince a court that the trees are having an adverse affect on your property and your enjoyment of it. If the court agrees with you they will issue an order requiring the neighbour to cut these trees back.

If the court does agree to make an order in your favour it can impose any conditions it thinks fit, including requiring the defendant to pay for any damage to your land or property or requiring you to pay for the cost of undertaking works.

## **Fences**

Your legal rights are covered by the Fencing Act 1978. Generally, if you want to build a fence on a common boundary, or upgrade an existing inadequate fence, you and your neighbour must share the cost of a basic fence.

Make sure you introduce yourself to your neighbour and be prepared to come up with a realistic proposal. Don't expect your neighbour to automatically have the same ideas on style, or budget as you.

If you can't reach an agreement, you can't just go ahead and put up a fence on the boundary line. You have to follow a process. First, you must serve a notice under the Fencing Act 1978 on your neighbour, giving the details of your proposal in writing. Your neighbour then has 21 days to serve a cross notice if they don't agree. You cannot start work during the 21-day period while you wait for a reply.

Schedule 1 to the Fencing Act 1978 contains a template notice which you should use; this can be viewed on the Government Legislation website.

If you reach a stalemate on notices and cross-notices, your options are to go to mediation, arbitration, the Disputes Tribunal or the District Court. Another option is to build a fence inside the boundary on your own property. You will have to pay for the entire fence yourself and your neighbour could still insist on a boundary fence at a later stage.

The height of the fence cannot be higher than two metres unless you get a building consent and, normally, planning consent from Council. The fence should be placed on the boundary line. If it is going to go more on one side than the other, this needs to be agreed by the owner on the other side.

If the owner doesn't agree you can seek a District Court order where there is no other practical alternative. The District Court may authorise you to enter the neighbour's property if this is necessary to build the fence, even if the neighbour is not contributing to the cost of the fence, and vice versa.

If a fence is damaged, you can pay to make immediate repairs to the fence and recover half of the costs from the neighbour.

If it has been destroyed and you need to replace it, it must be replaced with something similar. If you are responsible for the damage, for example, you flattened it with your car, you will have to pay to replace or fix it.

### **Council involvement**

Council has no jurisdiction in private disputes about trees or fences. This means the Council has no power to make you or your neighbour do anything where the dispute involves private property.

However, in the Matamata-Piako District several trees are listed as significant trees and are protected under the District Plan. There are substantial fines for ignoring protections, so before you start work on a tree, you should check with Council to see whether you need special permission.

If your tree is creating problems near a road or public land, Council can issue a notice ordering you to remove or trim it. This might happen if the tree is damaging roads, drains or other public amenities, or if it obstructs traffic or the view of road traffic. Several other statutory authorities also have this right.

If you want to challenge the Council's view you can apply to the District Court to have the notice set aside. But you will need to be quick: in some situations you will only have 10 days to do this. If you ignore the notice, Council can then enter your property and carry out the work. In this case you will have to accept the cost. In an emergency where there is danger to life, property or roading, then we can do this at your cost with only verbal notice being provided beforehand.

The Council must also look after its own trees and fences according to the same basic rules as everyone else. However, if you do live next to a Council reserve there will normally be a fencing covenant registered against the title to your land. This will prohibit you from asking Council to contribute to half the cost of a fence. You cannot ask Council, and Council cannot require you to contribute to the cost of a fence fronting a road.

If you do have any concerns in relation to Council land, the first step is to contact us to let us know there is a problem.

### **Resolving disputes**

If a tree owner and a distressed neighbour can't agree on what to do, several courses of action can be taken.

### **Mediation and arbitration**

Both mediators and arbitrators are available to help resolve a dispute. However, neither party can be forced to take part in either of these processes. A mediator will help you negotiate a solution to the dispute. An arbitrator will impose a solution. Mediation is less formal and usually less expensive, but cannot be enforced by a court unless you have included enforcement procedures in your agreement. An arbitrated settlement is backed by the courts.

Before you start, you should work out the likely costs. Mediation and arbitration are charged on a time basis. Both parties are expected to pay an equal share, unless another agreement is reached.

### **Disputes Tribunals**

Disputes Tribunals can hear claims for damages to property for amounts up to \$15,000 (or \$20,000 if the parties agree). Typical examples are claims for damage to drains, driveways, foundations and fences.

Although a tribunal referee will generally not be able to hear claims when the dispute is over loss of light, sunshine, views, or involves removal or trimming of the tree. In this case, a referee can try to help the two sides reach agreement. If your neighbour decides to ignore this, you will have to go to the District Court to try to get the problem resolved.

### **District Court**

Claims for any value, or claims that involve the loss of light, sunshine, views, or that involve the removal or trimming of trees, can be taken to a District Court. Claims through the District Court will almost certainly require the help of a lawyer and can be expensive.

To find out more about New Zealand Legislation go to:  
[www.legislation.govt.nz](http://www.legislation.govt.nz)

### **Disclaimer**

This publication is intended as a general guide and is not intended to be a substitute for advice from a legal professional. If a dispute arises that relates to any of the issues in this publication you should consult your lawyer.

**Appendix 11 Sample tree evaluation form and report**

**ISA TREE EVALUATION FORM**

Site Address

Owner:

Date:

Inspector:

**Tree Characteristics**

Tree Number:

Species:

DBH:

# of Trunks:

Height:

Form:

Crown Class:

Age Class:

Pruning History:

Crown cleaned

Crown lifted

Thinned

Cable Braced

Special Value:

Specimen

Heritage/Historic

Protected

Shade

**Tree Health**

Foliage Colour:

Foliage Density:

Foliage Size:

Annual Shoot Growth:

Woundwood Development:

Vigor:

Major Pests or Diseases:

**Site Conditions**

Site Character:

Recent Site Disturbance:

Landscape Type:

Irrigation:

% Dripline Paved:

% Dripline w/Fill Soil:

% Dripline Grade Lowered:

Soil Problems:

Slope:

Aspect:

**Obstructions:**

**Exposure to Wind:**

**Prevailing Wind Direction:**

**Target:**

**Use Under Tree:**

**Parking**

**Pedestrian**

**Landscape**

**Can Target be Moved:**

**Can Use Be Restricted:**

**Occupancy:**

**Tree Defects:**

**Root Defects**

**Suspect Root Rot:**

**Mushroom/Conk/Bracket Present:**

**ID:**

**Exposed Roots:**

**Undermined:**

**Lean:**

**Decay in Lean Plane:**

Root Pruned:

Distance From Trunk:

Soil Heaving:

Restricted Root Area:

Buttress Wounded:

Roots Broken:

Soil Cracking:

Potential For Root Failure:

**Crown Defects**

<b>Defect</b>	<b>Root Crown</b>	<b>Trunk</b>	<b>Scaffolds</b>	<b>Branches</b>
<b>Poor Taper</b>				
<b>Bow/Sweep</b>				
<b>Codominants/Forks</b>				
<b>Included Bark</b>				
<b>Excessive End Weight</b>				
<b>Cracks/Splits</b>				
<b>Hangers</b>				
<b>Girdling</b>				

<b>Wounds/Seams</b>				
<b>Decay</b>				
<b>Cavity</b>				
<b>Mushroom/Bracket</b>				
<b>Bleeding Sap</b>				
<b>Loose/Cracked Bark</b>				
<b>Nesting Hole/Bee Hive</b>				
<b>Deadwood/Stubs</b>				
<b>Borers</b>				
<b>Cankers/Galls/Burls</b>				
<b>Previous Failure</b>				

**Hazard Rating**

**Tree Part Most Likely to Fail:**

**Inspection Period:**

**Failure Potential +**

**Size of Part +**

Failure Potential: 1 - Low, 2 - Medium, 3- High, 4 - Severe

Size of Part: 1 - < 15cm, 2 - 15 - 45 cm, 3 - 45 - 75 cm, 4 - >75 cm

Target Rating: 1 - Occasional Use, 2 - Intermittent Use, 3 - Frequent Use, 4 - Constant Use

Target Rating

Hazard Rating

**Hazard Abatement**

Prune:

Cable Brace:

Inspect Further:

Move Target:

Remove Tree:

Replace Tree:



**Tree Health**

Foliage Colour: Foliage Density: Normal Foliage Size: Normal Annual Shoot Growth: Average

Woundwood Development: Average Vigor: Average

Major Pests or Diseases:

**Site Conditions**

Site Character: Residence Open Space Recent Site Disturbance: None

Landscape Type: Lawn Irrigation: None

% Dripline Paved: 10-25% % Dripline w/Fill Soil: <10% % Dripline Grade Lowered: <10%

Soil Problems:

Slope: Aspect:

Obstructions:

Exposure to Wind: Single Tree

Prevailing Wind Direction: SW

**Target:**

Use Under Tree: Parking Pedestrian Landscape

Can Target be Moved: No Can Use Be Restricted: No

Occupancy: Occasional Use

**Tree Defects:**

**Root Defects**

Suspect Root Rot: Yes Mushroom/Conk/Bracket Present: No ID:

Exposed Roots: Low                      Undermined:                      Lean: Natural                      Decay in Lean Plane: No  
Root Pruned: No                      Distance From Trunk:                      Soil Heaving: No  
Restricted Root Area: Low                      Buttress Wounded: Yes                      Roots Broken: No                      Soil Cracking: No  
Potential For Root Failure: Low

**Crown Defects**

Defect	Root Crown	Trunk	Scaffolds	Branches
Poor Taper				
Bow/Sweep				
Codominants/Forks				
Included Bark				
Excessive End Weight				
Cracks/Splits				
Hangers				

Girdling				
Wounds/Seams	Moderate	Moderate		
Decay	Moderate	Moderate		
Cavity	Moderate	Moderate		
Mushroom/Bracket				
Bleeding Sap				
Loose/Cracked Bark				
Nesting Hole/Bee Hive				
Deadwood/Stubs				
Borers				
Cankers/Galls/Burls				
Previous Failure				

**Hazard Rating**

Tree Part Most Likely to Fail:

Trunk at Cavity

Inspection Period:

Yearly

Failure Potential: 1 - Low, 2 - Medium, 3- High, 4 - Severe

Failure Potential +

1

Size of Part: 1 - < 15cm, 2 - 15 - 45 cm, 3 - 45 - 75 cm, 4 - >75 cm

Size of Part +	4
<u>Target Rating</u>	<u>3</u>
<u>Hazard Rating</u>	<u>8</u>

Target Rating: 1 - Occasional Use, 2 - Intermittent Use, 3 - Frequent Use, 4 - Constant Use

**Hazard Abatement**

Prune:

Cable Brace:

Inspect Further:      Yearly inspections recommended

Move Target:      No

Remove Tree:      No

Replace Tree:      No

*Sample Report*

**STEM Report and Hazard Assessment  
Relating to:**

**An Elm Tree and a Tulip Tree At Waharoa School.**

**For :** The Matamata-Piako District Council

**Attention:** Bryan Turner

**Prepared by:** Philip Sale  
B.Sc. (Tech)  
Diploma in Arboriculture

Date: 6th March 2009

6th March 2008

Matamata-Piako District Council  
PO Box 266  
Te Aroha

## **1 Introduction**

### **1.1 Brief**

I have been instructed to inspect these trees and carry out a STEM evaluation and a Visual Tree Assessment and hazard assessment.

The report is also to include recommendations for remedial works if necessary.

### **1.2 Qualifications and Experience**

I have based this report on the information provided to me along with my observations from the site. My conclusions were made based on analysis and my interpretation of this information. My qualifications and experience are listed in Appendix 5

## **2 Site Visit and Observations**

### **2.1 Site Visit**

I visited the site on the 5th of March 2009, at this time the weather was overcast with a moderate breeze. The purpose of this visit was to inspect the site and carry out a tree inspection and assessment.

During this site visit I took photos located in Appendix 1

### **2.2 Site Description**

The site is a school ground on Ward Street Waharoa.

### **2.3 Identification and Location of the Trees**

The trees are a large mature *Ulmus* spp. (Elm Tree) and a *Liriodendron tulipifera* (Tulip Tree) growing in a grass area near the main entrance into the school.

### **2.4 Tree Description and Observations**

The Elm Tree - This tree is a large mature Elm Tree that is 33 metres tall with a trunk diameter at 1.4 metres above ground level of 1.50 metres and a crown spread of 26 metres. The tree has a single trunk splitting into a multi-leadered upright crown. The form of this tree is a typical upright shape. This tree appears to have restructured from a pollard some years ago.

Near the point of the crown break there has been a large leader broken from the tree. At the point of this tear there are two other leaders connected with an included union. The wound from the torn out limb has undermined the included union of the two remaining leaders on this part of the crown. It appears that approximately 50% of the wood has been removed from the area beneath this union.

The area beneath this tree is used for traffic, parking, pedestrians and buildings.

This tree gained a STEM score of 162 points (See Appendix 3)

The Tulip Tree - This tree is a large mature tulip tree that is 33 metres tall with a trunk diameter at 1.4 metres above ground level of 2.07 metres and a crown spread of 24 metres.

The tree has a single trunk splitting into a multi-leadered upright crown. The form of this tree is a typical spreading shape. This tree appears to have restructured from a pollard some years ago.

The low branches extend over the footpath towards the road. There is also some smaller deadwood throughout the crown.

This tree gained a STEM score of 162 points (see Appendix 3)

### 3 Hazard Assessment

An inspection was carried out using a systematic Visual Tree Assessment (VTA).

The International Society of Arboriculture (ISA) Tree Hazard Evaluation Form 2nd Edition (Matheny and Clark 1994) was filled out on site. This was then used in conjunction with The New Zealand/Australian Standard for Risk Management (AS/NZ 4360:1999) to calculate a hazard rating, risk priority, and to design and prioritise remedial actions.

See Appendix 4 for detailed methods.

#### 3.1 ISA Tree Hazard Evaluation

The Elm Tree- A hazard rating has been calculated for this tree using the ISA Tree Hazard Evaluation Method (see appendix 2).

$$\begin{array}{rcccc} \text{Failure Potential} & + & \text{Size of Part} & + & \text{Target Rating} & = & \text{Hazard Rating} \\ 3 & & 3 & & 4 & & 10 \end{array}$$

This tree scores a hazard rating of 10 out of a possible 12.

The Tulip Tree - A hazard rating has been calculated for this tree using the ISA Tree Hazard Evaluation Method (see appendix 2).

$$\begin{array}{rcccc} \text{Failure Potential} & + & \text{Size of Part} & + & \text{Target Rating} & = & \text{Hazard Rating} \\ 2 & & 2 & & 4 & & 8 \end{array}$$

This tree scores a hazard rating of 8 out of a possible 12.

The ISA Method is useful to determine priority levels for works but does not give a true indication of the risk associated with the tree. To get a more useful indication of the risk the ISA Method is combined with the The Australian/New Zealand Standard for Risk Management.

#### 3.2 The Australian/New Zealand Standard for Risk Management

The failure potential score from the ISA Tree Hazard Evaluation Form was then used with "The Australian/New Zealand Standard for Risk Management As/Nz 4360:1999", to complete the Risk Priority Matrix (shown below)

### As/Nz 4360:1999 Risk Priority Matrix

Impact		Negligible	Minor	Major	Catastrophic
Likelihood		1	2	3	4
Likely	4	Moderate	High	High	Extreme
Possible	3	Moderate	Moderate	High	Extreme
Unlikely	2	Low	Low	Moderate	High
Rare	1	Low	Low	Moderate	Moderate

The impact descriptors are as follows:

Negligible	No injuries, No damage
Minor	First aid treatment, Small damage to property
Major	Medical treatment required, Major damage to property
Catastrophic	Extensive injuries or death, Extensive damage to property

The results of this analysis are as follows:

The Elm Tree

Likelihood	Impact	Outcome
3	4	Extreme

Where an outcome of Extreme is gained from the matrix the response should be to take immediate remedial action.

In this situation there are several options that should be considered.

#### Option 1

Remove the tree. This option is the most severe option but will completely remove any risk of future failure of this tree.

#### Option 2

Remove the outer affected leader and pollard the other included stem to  $\frac{1}{2}$  to  $\frac{2}{3}$  of the current height. The rest of the crown would then need to be pruned to blend the crown in and remove any excessive end weight.

This option will reduce the risk of failure from this wound and reduce the impact of a failure as the pollarded leader would be at a height that should it fail it will not reach the classroom, It will also retain the size and scale of the tree.

With this option there is still the possibility that further leaders could fail.

#### Option 3

Heavily reduce the entire crown. This option will reduce the chance of any of the leaders failing in the future. It will however leave many large pruning wounds that will be potential sites for disease and decay organisms to enter the tree. This option will also reduce the size and scale of this tree.

With this option there is still the possibility leaders and branches could fail and as any decay develops in the structure of the tree its structural integrity could be further reduced in the future.

The Tulip Tree

Likelihood	Impact	Outcome
2	3	Moderate

Where an outcome of Moderate is gained from the matrix the response should be to review and monitor.

In this situation it would be prudent to crown lift and weight reduce the lower branches and remove the major deadwood.

## **5 References**

Clark Janes & Matheny Nelda (1994). A Photographic Guide to the Evaluation of Hazard Trees in Urban Areas. Savoy, Illinois: International Society of Arboriculture.

Mattheck C. & Breloer H. (1994) The Body Language of Trees. London: HMSO.

**Appendix 1 Photos**



**Photo1 The Elm Tree**



**Photo 2 The split out area**



**Photo 3 The split out area with the leader union above it.**



**Photo 4 The Tulip Tree**

## **Appendix 4 Methods**

### **VTA**

VTA is a three-step process.

A visual inspection for defects symptoms and vitality is carried out. If there is no sign of a problem the investigation is concluded

If a defect is suspected on the basis of symptoms, its presence or absence must be confirmed by thorough examination.

If the defect is confirmed and appears to be a reason for concern it must be measured and the strength of the remaining part of the tree evaluated.

(Matthek and Breloer 1994)

When carrying out VTA the main defect symptoms to be looked for are ridges, bulges and hollows or depressions as well as the obvious cavities, dead wood and disease..

Bulges can be a sign of hollow areas. The bulges are the result of the tree producing reaction wood around a hollow area as it strives to conform to the axiom of uniform stress.

Hollows or depressions in the trunk can be a sign of the tree being unable to produce enough reaction wood to counter a defect. If this is the case the tree could be in a serious condition.

### **ISA Tree Hazard Evaluation Method**

A hazard rating method has been developed by the International Society of Arboriculture that awards points from 1 to 4 for each of three criterions.

#### **Failure Potential**

**Low:** Defects are minor

**Medium:** Defects are present and obvious

**High:** Numerous and or significant defects present

**Severe:** Defects are very severe

#### **Size of defective part most likely to fail**

<150mm

150 to 450mm

450 to 750mm

>750mm

#### **Target Rating**

Occasional use

Intermittent use

Frequent use

Constant use

These are than added to give a rating between 3 and 12 that can then be used to aid decisions on any hazard abatement works required.

The Australian/New Zealand Standard for Risk Management  
As/Nz 4360:1999 contains a six-step process:

Establish the context. Significance, protection etc.

Risk Identification, what is the potential for the tree to fail

Risk assessment, what is the degree of risk  
 Risk evaluation, what risks should be treated  
 Risk treatment, what treatments can be used  
 Monitoring and reviewing, communication and consultation.

Steps 3 and 4 can be carried out with the aid of the risk priority matrix

**The risk priority matrix**

Impact		Negligible	Minor	Major	Catastrophic
Likelihood		1	2	3	4
Likely	1	Moderate	High	High	Extreme
Possible	2	Moderate	Moderate	High	Extreme
Unlikely	3	Low	Low	Moderate	High
Rare	4	Low	Low	Moderate	Moderate

The likelihood descriptor can be substituted for the failure potential from the ISA hazard evaluation form.

**The impact descriptors are as follows:**

- Negligible** No injuries, No damage
- Minor** First aid treatment, Small damage to property
- Major** Medical treatment required, Major damage to property
- Catastrophic** Extensive injuries or death, Extensive damage to property

The action required can then be taken from the matrix as follows:

- Low** Take no action
- Moderate** Review, monitor
- High** Take some remedial action
- Extreme** Take immediate action

**Appendix 5 Qualifications and Experience**

Philip O Sale BSc. (TECH), Diploma in Arboriculture

**Qualifications:**

- Bachelor of Science and Technology (Waikato University) 1995
- Advanced Certificate of Arboriculture (Waikato Polytechnic) 1998
- Diploma in Arboriculture with Distinction (Waikato Institute of Technology) 2007

NZAA:

Elected as a member on the Executive of the New Zealand Arboriculture Association from November 2003 to November 2005.

Publications:

“Decay and Deadwood - Are we too quick to make the final cut? The ecological importance of dead and dying trees should be considered by the Arborist.” Sept 2005 Issue 27 Tree Matters The Magazine of the New Zealand Arboricultural Association INC.

“Anthracnose rips through Hobbiton. Biological warfare in middle earth?” December 2003  
Issue 20 Tree Matters The Magazine of the New Zealand Arboricultural Association INC.

NZAA Conferences:  
New Plymouth (2002)  
Tauranga (2003)  
Queenstown (2004)  
Auckland (2005)  
Christchurch (2007)  
Hamilton (2008)

**Experience:**

Arbor Care Limited: (2000 to present). I have been working as a project manager, working in all aspects of arboriculture. I have been undertaking tree inspections for Councils, developers and private customers. I have prepared reports on structural integrity; Health and Safety; and for the purposes of obtaining resource consents for subdivisions and building projects.

I have just completed a survey of Tauranga City Councils' protected trees and have carried out over 2000 STEM Evaluations, probably more than any other person in New Zealand.

I have appeared in the District Court, The Environment Court, the Disputes Tribunal, and at resource consent hearings as an expert witness.

Dryad Tree Specialists (United Kingdom): (1999 to 2000). I was employed as an arborist carrying out all aspects of practical arboriculture for Councils, Private Customers and the National Trust.

Hort Research: (1996 to 1998.) I was working as a Research Technician involved in projects developing natural controls for forestry and horticultural diseases.

Forest Research Institute: (1995). I was working as a research assistant involved in projects developing accurate carbon budgets for the New Zealand exotic forestry estate.

## Appendix 12 Guide to shrubs groundcovers and rain garden plants

Below is a list of species for use within distinct character areas that have been identified. The list is not conclusive; nor does it restrict plantings to these species only or provide guidance for species selection within natural areas and specific character areas.. It is a guideline produced from site evaluation, trial and error and takes into account selection criteria such as environmental, establishment, production, impact and manageability.

### Shrub Species

#### 1. to 2 metres

Abelia	Deutzia	Philadelphus
Acer spp standards	Edgeworthia	Pieris
Acuba	Enkianthus	Raphiolepis
Azaleas	Escallonia	Rhododendron
Azaleas (deciduous)	Grevillea	Sophora
Calliandra	Grewia	Virburnum
Callistemon	Hydrangea	
Camellia	Kolkwitzia	
Ceanothus	Leptospernum	
Choisya	Mahonia	
Coleonema	Myrtus	
Coprosma spp	Nandina	
Corokia	Oleria	

#### Under 1 metre

Arthropodiums	Eriostemon	Nandina
Astelia	Euryops	Pieris
Azaleas	Forsythia	Rhododenron
Brunfelsia	Gardenia	Rosmarinus
Buxus	Grevillea	Sarcococca
Ceanothus	Hebe	Sophora
Chaenomeles	Hydrangea	Spiraea
Coleonema	Hypericum	
Convolvulus	Lavendula	
Coprosma	Leptospernum	
Dampiera	Leucothoe	
Daphne	Lithodora	
Deutzia	Loropetalum	

## Rain Garden Species

Astelia grandis  
Baumea spp  
Carex testacea  
Carex secta  
Carex maoricacarex coriacea  
Cordyline spp

Phormium spp  
Leptocarpus similis

It is important to note that plant selection for rain gardens, needs to take into account that the plants whilst having to tolerate extremely wet conditions, there are also periods where the gardens are extremely dry.

The design of the gardens takes into account that the soil could be replaced anywhere between intervals of 5 to 20years depending on the efficiency and loading of the device, so plants should be easily replaceable.

Selection is important and further advice should be sort to select species that can withstand long dry periods with intermittent periods where the plants may be under water for a couple of days. It is also important to select plants that are known filter plants such as Leptocarpus similis.

### **3.0 Glossary**

The following definitions are given for words and terms found within the texts and appendices of the District Tree Strategy

#### **Adventitious Growth**

That arises from (normally) suppressed buds, or from those plants which invade or inhabit a site first.

#### **Amenity Tree**

Trees located within the Matamata-Piako District Amenity Tree Area that are either: (a) 6 metres or more in height; or (b) replacement trees installed as a requirement of a resource consent. Some tree species, such as willow, brush wattle and some species of cypress, are excluded from District Plan rules regarding amenity trees.

#### **Amenity value**

Provides positive features and qualities in the landscape.

#### **Approved arborist**

A suitably qualified person who can demonstrate proven experience, competency and ability in the field of arboriculture.

#### **Arboricultural**

The operational instruction manual that sets out the standard method for Operations Manual contractors to follow when commissioned to carry out arboricultural work.

#### **Arboriculture**

The establishment, management and maintenance of amenity trees.

#### **Arterial routes**

Route or road of regional or district strategic importance as identified on the MPDC District Plan Maps.

#### **Branch collar**

The raised rim of bark tissue at the connection point between a branch or stem.

#### **Bush remnant**

Areas of indigenous (native) vegetation that represent the original habitat type of an area. These remnants contribute to the aesthetic value of the district and to local biodiversity.

#### **Cambium zone**

The area of dividing tissue within a tree found between the outer bark and the woody stem.

#### **Canopy**

The extent of the foliage cover of any tree or plant.

#### **Carriageway**

Area designated for vehicular movement.

**CODIT** An acronym for the term Compartmentalisation of Decay in Trees, meaning a two part descriptive model on the process of decay in a tree.

**Commemorative trees**

Trees planted on public land to commemorate a person or event. Trees are also donated by individuals and organisations.

**Compaction**

Ground that has hardened/compressed as a result of constant wear by environmental or mechanical means

**Covenant**

Legal mechanism that provides agreement to protect a feature.

**Crown**

The live branches and foliage of a tree

**Crown lifting**

Removing the lower branches of a tree to provide clearance for buildings, vehicles, pedestrians, services and vistas. Lifting is carried out to no greater extent than 1/3 the overall height of the tree in proportion to the tree's canopy.

**Crown thinning**

Removal of dead, declining and secondary growth to increase air movement and light through the crown. Thinning is carried out to no greater extent than 20% of the canopy in proportion to its size.

**Cultivar**

Variations of plant species specifically selected and produced by people.

**Directional pruning**

Removal of branches at the stem to encourage overall growth away from a feature or fixture.

**Dripline**

Generally, the area beneath the canopy of a tree, measured at ground level from any part of the surface of the trunk, with a radius of 5 metres or to the outermost extent of the spread of its branches, whichever is the greater.

**Ecological**

Modes of life, habits and relationships of living organisms and their environment.

**Eco-sourcing**

Replanting with only locally occurring natural genetic plants materials.

**Edge effects**

A change in species composition, physical conditions, or other ecological factors at the boundary between two ecosystems. In the case of a bush remnant, an abrupt edge along a remnant can modify the light, temperature, wind exposure within the remnant.

**Encroachment**

A situation where the public recreational use or appreciation of the reserve is reduced or obstructed by the private use of the reserve. Alternatively when roots or branches of a tree grow over or into neighbouring property.

**Endemic**

Refers to a plant found only in a particular area.

**Environment**

The physical and biological factors within a given site.

**Ephemeral**

Lasting a short time

**Exotic**

Plant or animal introduced from another country.

**EW**

Environment Waikato

**Food web**

A complex of interrelated food chains in an ecological community.

**Formative pruning**

Pruning a tree to enhance the branch structure in relation to a tree's long term shape and structural strength.

**Guardianship**

Providing for the fostering and care of a feature or entity.

**Hapu**

Subtribe, usually a number of whanau with a common ancestor.

**Hazardous tree**

A tree which has physical, structural and/or biological defects that has been identified or evaluated, using a standard evaluation method such as ISA Tree Hazard Evaluation, as representing danger to life or property.

**Hearings Commission**

A standing committee established from time to time by the Council, and consisting of elected Councillors, to hear and determine matters regarding Acts, regulations and policy, including matters of the District Tree Policy and items of appeal on tree related issues.

**Indigenous**

Plant or animal that occurs naturally to an area.

**Intrinsic value**

Something valued 'just because it exists' i.e., apart from any economic, cultural, social or historic worth.

**ISA**

International Society of Arboriculture. A world-wide organisation representing professional arborists.

**ISA Tree Hazard Standard Evaluation Method**

Evaluation method that identifies the hazard rating of trees.

**Iwi**

Tribe or grouping of people with tribal affiliations

**Landscape values**

Those features of the land that make up the wider visual appreciation of an area when viewed as a whole, such as trees, vegetation, water, landform.

**Land vesting in Council**

An area of land turned vesting in the Council as a condition or outcome of sub-division or other development process.

**Late successional vegetation**

Vegetation which will ultimately form the canopy of the forest area or final stage of succession.

**Local native species**

Local native species are those species of indigenous trees known to naturally occur within the 'ecological districts' within The Waikato District. Ecological districts are contiguous geographic zones having common ecological characteristics, including plant species composition. Ecological districts have been mapped throughout New Zealand and their species composition described.

**Local character**

Those species that define the local character of the district.

**Local pioneer species**

Plants that establish easily and provide the first tree cover, occurring naturally in the district.

**Long term value**

Providing positive and useful effects over a long period. Usually over 50 years.

**Mana whenua**

Customary authority and title exercised by an iwi or hapu over land and other taonga within the tribal rohe.

**Mitigate**

Moderate or neutralise the effects of an activity.

**MPDC**

Matamata-Piako District Council

**MPDC Website**

[www.mpdc.govt.nz](http://www.mpdc.govt.nz)

**Non endemic native plants**

Native plants that are not found naturally in the Waikato Ecological Region.

**Notable tree**

A tree or group of trees that are considered significant for their historical, botanical, landscape, amenity or cultural values and are identified as such in the MPDC District Plan

**NTP (Natural Target Pruning)**

An abbreviation for the term Natural Target Pruning - a model demonstrating the proper position and sequence of cuts to be made when pruning.

**NZAA**

New Zealand Arboricultural Association. A national organisation representing professional arborists.

**Pioneer species**

One of the first naturally arising plant species to appear on any landscape

**Pollarding**

A pruning method of training branches, used on some large-growing trees, where the tree is pruned to the same growth points (annually or regularly), to maintain the crown to a particular size.

**Proactive**

Activity carried out before it becomes a necessity.

**Reactive**

Activity that is carried out in direct response to an enquiry or observation.

**Reduction pruning**

The shortening and/or removal of select branches within a tree to reduce the overall size of the tree canopy.

**Regenerative pruning**

The removal and/or pruning of branches or stems to encourage a plant's recovery from damage or stress.

**Remedial pruning**

Pruning to correct imbalances or deformities in tree shape and form, to reduce duplication in branch formations, to remove damaged tissue (includes deadwood).

**Remnant**

The natural vegetation remaining from an original tree stand or plant colony which has been modified.

**Reserve management plan**

A management plan provided for in s. 41 of the Reserves Act (1977). Management planning under the Reserves Act is intended to enable the administering body for a reserve to establish the desired mix of uses and values and set in place policy to guide day to day management.

**Riparian area**

A riparian area is a margin of trees and other vegetation adjacent to a watercourse that forms a transition area between the aquatic and terrestrial environment.

**RNZIH evaluation method**

A national standard (compiled by the Royal New Zealand Institute of Horticulture) used to assess the contribution of a tree(s) within the landscape, using a points system to determine health, condition and monetary value.

**Road reserve tree**

Trees situated on Council road reserves that have not been formally planted.

**Rohe**

A territory or boundary that defines an area within which a tangata whenua group claims traditional association and manawhenua

**Root zone**

The area covered by the full extent to which roots spread from a tree(s).

**Short term value**

The limited contribution, in terms of lifespan and/or beneficial attributes, of a tree or plant within any landscape. The time scale is usually less than 50 years duration.

**Significant Natural Area**

An area of indigenous vegetation or a habitat of indigenous fauna that meets the criteria in Appendix 1 (part 5) and is identified in Schedule 3 in the District Plan. An exception is that no vegetation that has regenerated since the District Plan was notified must be regarded as a Significant Natural Area, as negotiated and approved through consent order from the Environment Court.

**Significant tree**

A tree identified as having long term life expectancy and/or high amenity value.

**Solar access**

The availability or penetration of sunlight.

**Structural safety**

The inherent capacity of a tree or plant, observed by examination of its structure, shape and form, to withstand wind loading and/or other physical force in order to resist failure, breakage or collapse.

**Sucker growth**

Fleshy shoots and growth arising from below a graft union or from the base of a tree or plant.

**Suppressed growth/branches**

Branches or stems under severe stress due to competition for light or nutrient. Usually these branches or stems will die in the short term.

**Sustainability**

The capacity to endure or maintain any given level of activity or appearance.

**Sustainable trees**

Road reserve and street trees that are considered, through established assessment methods, to be 'manageable' in relation to surrounding activities, services, assets, properties and infrastructure.

**Taonga**

Treasure or property that are prized and protected as sacred possessions of tangata whenua as determined by tangata whenua.

### **Topping**

A lay person's term meaning the removal of the head or top most section of a tree or plant. Topping is not an accepted professional arboricultural practice for two reasons:

- It promotes decay that can result in eventual tree decline and death; and
- For many species, topping leads to over-stimulation of re-growth, resulting in a worse problem than one started with.
- Topping is not to be confused with the practice of pollarding, which, if done correctly poses no adverse effects upon the tree.

### **Trade-off**

A negotiated outcome that provides benefit to all parties and may mean limited compromise.

### **Tree**

Tree means a perennial woody plant at least 6 metres in height at maturity, having an erect stem/s or trunk/s and a well-developed crown or leaf canopy.

### **Tree isolation systems**

Built structures or manufactured products that isolate a tree from potential damage (such as a protective cage or ground-level surround that prevent damage from stock or mechanical damage).

### **Tree collection**

Groups of trees formally planted and managed at a site to enhance the diversity and value of the district tree asset. May be single or multi-species.

### **Unsustainable trees**

Road reserve and street trees that are determined, through established assessment methods on an as needs basis, to have an unmanageable level of interference with surrounding activities, services, properties and infrastructure.

### **Urban tree collection**

A formal planting of specialised botanical or feature interest. Usually designed, recorded and maintained as a long term permanent asset.

### **Urban viewshaft**

A view from a public place, such as a road or reserve located within an urban area, that contributes significantly to the visual amenity of that urban area. The location and extent of view shafts are show on in the Planning Maps for the District Plan.

### **Valuable tree**

A tree identified, through RNZIH assessment using established criteria, as having;

- Long term life expectancy of > 30 years; and
- A significant role in the locational setting, which includes its contribution to amenity and ecological values.

Tree species identified as plant pests (nationally or regionally) will generally not be evaluated as 'valuable'.

### **Vista**

A view, view shaft or framed view point.

### **Waahi tapu**

Places or things that are sacred or spiritually endowed and includes, but is not limited to: pa, area (tracks), urupaa, battle sites and Tauranga waka (canoe landings)

## **Acknowledgements**

New Plymouth District Council – District Tree Policy – Guidelines for the layout of this document.

Hamilton City Council – Hamilton Development Manual – Guidelines for part of this document.

Thames Coromandel district Council – For the idea to create individual Town Strategies.