

W = 1050 minimum

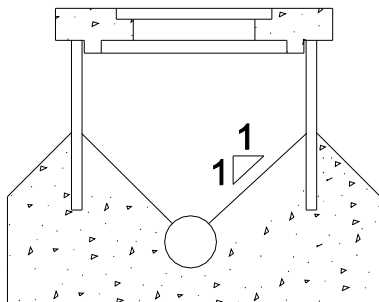

675 SHALLOW CHAMBER

(To be used only on pipe sizes of 100mm to 150mm and where depth of invert is less than 1000mm)

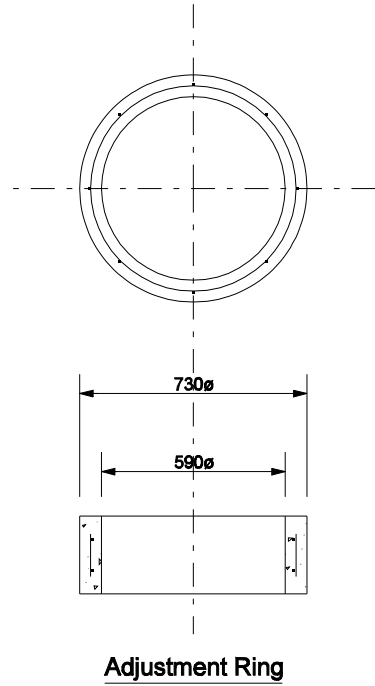
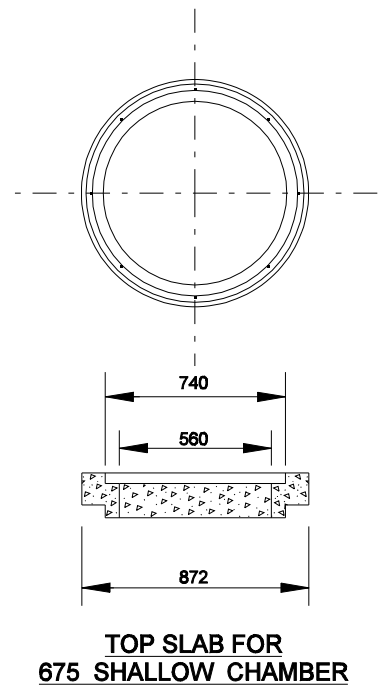

Not To Scale